

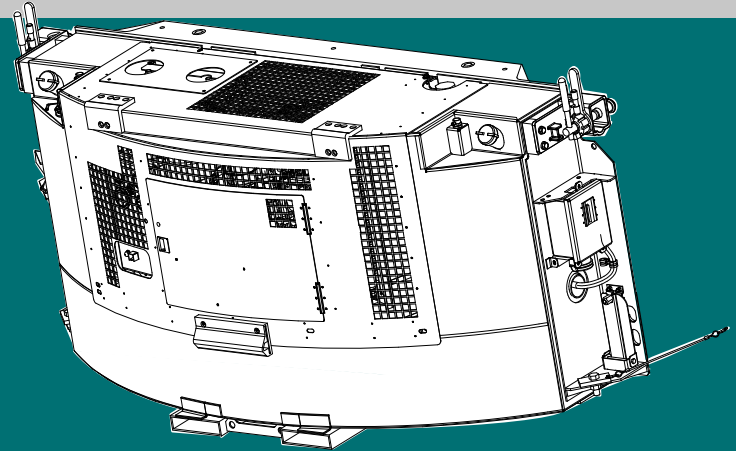

Diesel Generator Set

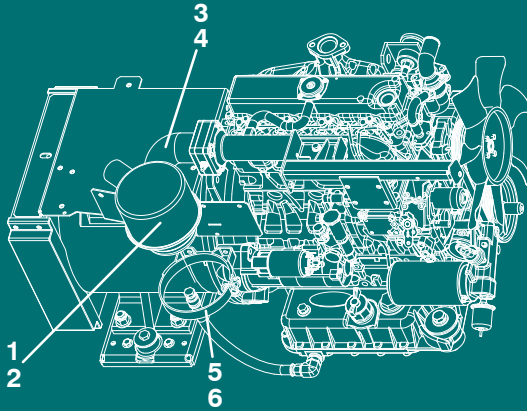

SERVICE PARTS LIST for 69RG15

Generator Set Units:
PID RG1400 Series
PID RG1500 Series
PID RG1600 Series
PID RG1700 Series
PID RG1800 Series
PID RG1900 Series



TRANSICOLD

**SERVICE PARTS LIST
DIESEL DRIVEN GENERATOR SET**

**MODEL
69RG15**

TABLE OF CONTENTS

PARAGRAPH NUMBER	Page
INTRODUCTION	i
MODEL AND PRODUCT IDENTIFICATION (PID) NUMBERS	i
ORDERING INSTRUCTIONS	i
GENERAL NOTES	i
PAINTED PARTS COLOR SYSTEM	ii
MODEL CHART	iii
1 RG GENSET CONFIGURATION	2
2 UNIDRIVE	4
3 UNIT MOUNTING	8
4 COOLANT SYSTEM	10
5 FUEL SYSTEM	12
6 AIR FILTERS	16
7 CONTROL BOXES	18
8 SOLID STATE BATTERY CHARGER	27
9 VOLTAGE	28
10 BATTERIES	30
11 EXHAUST SYSTEM	32
12 LABELS	34
13 SKINS OPTION	36
14 RECEPTACLE BOX ASSEMBLY	50
15 WIRE HARNESS	56
16 RETROFIT KITS	58
PART NUMBER INDEX	Index-1

INTRODUCTION

This parts list identifies service replacement parts for the Carrier Transicold Diesel-Driven Generator Set listed in the model chart below. This parts list does not include detailed replacement parts for the engine listed in the first chart below. Detailed parts identification for these items may be found in the applicable parts list. The form numbers for the engine omit revision dash numbers. For example, the latest engine list may have a -01 added to the basic number to read 62-03459-01. Therefore, when forms are ordered the latest revision will be sent.

MANUAL/ FORM NO.	ENGINE PART NO.	EQUIPMENT COVERED	TYPE OF MANUAL/FORM
62-03741	26-00128-22	CT4-134-DI	Workshop
62-03459	26-00128-22	CT4-134-DI	Engine Parts List

MODEL AND PRODUCT IDENTIFICATION (PID) NUMBERS

Beginning with early 1995 production, in addition to a model number, Carrier Transicold began using a parts identification (PID) number in the format of RG0000. In this manual, the PID number is shown in boldface to point out variations within models. Please include the PID number, in addition to the model number, when ordering and inquiring about your unit.

ORDERING INSTRUCTIONS

All orders and inquiries for parts must include:

- Part Identification Number (**PID**)
- Unit Serial Number
- Part Number
- Description of Part
- Quantity Required

Address all correspondence for parts to the following address:

CARRIER TRANSICOLD DIVISION
Replacement Components Group
TR-20, P.O. Box 4805
Syracuse, New York 13221
or
Fax to: (315) 432-3778

GENERAL NOTES

To find replacement parts, consult table of contents, and turn to the appropriate page for the illustrated breakdown of replacement parts. The following letter designations are used to classify parts throughout this list:

- A/R *As Required.*
NSS *Not Sold Separately* – Order next higher assembly or kit.
PID *Parts Identification Number* – essential to identify unit configuration.
PL *Purchase locally.*
SST *Stainless Steel* – 300 Series unless otherwise specified.
SV *Suffix SV* – added to the part number designates service part replacement part.

PAINTED PARTS COLOR SYSTEM

Available paint colors: (Other than White Cloud or Hull Blue)

PAINT COLOR	PART NO.
Sky Blue	36-00048-28
Flame Orange	36-00048-27
Citrus Orange	36-00048-29
Raven Black	36-00048-04
Red	36-00048-57

Overview of the new numbering system:

A typical part number appears as: 79-01741-00 (access door). To order an access door in sky blue you add the last three digits of the special color paint and then add the specific dash number for the color of that paint.

For example:

Sky blue paint P/N is 36-00048-28.
The last three digits of the blue paint are: 048
The specific dash number is: 28

The painted parts system looks like this:

79-01741-00 Standard P/N for the access door.
048 Last 3 digits of special color paint.
28 Specific dash # for color of paint.

79-01741-0004828 P/N For Special Painted Door

Data Entry Note:

The above is how you should see most parts being ordered. Certain customers may have a character constraint that will only allow them to input 14 characters in their system and our new painted part numbers are 16 characters long. Therefore, they will be ordering these parts without the dashes, which will look like the following, 79017410004828.

MODEL CHART

NOTE

The numbers shown in the model chart below refer to the section numbers that cover that option.
Please refer to the table of contents for page numbers.

Model Number	PID Number	Schematic/ Wiring Diagram Decals	Fuel Tank Assembly Service Part Number	Undrive	Unit Mounting	Coolant System	Fuel System	Air Filter	Control Box	Voltage	Battery Charger	Battery	Exhaust System	Labels	Skins Option	Receptacle	Wire Harness
1400 Series Standard																	
69RG15-130C-05	RG1405	62-11292-00	86-04301-14	2.a 2.b	3.b	4	5.b	6.a	7.a	9.a	8	10.b	11.a	12	13.c	14.a	15.c
	RG1411	62-11292-00	86-04301-14	2.a 2.b	3.b	4	5.b	6.b	7.a	9.a	8	10.b	11.a	12	13.c	14.a	15.c
69RG15-130C-07	RG1403	62-11419-00	86-04301-10	2.a 2.b	3.b	4	5.b	6.a	7.d	9.b	8	10.b	11.b	12	13.b	14.d	15.b
	RG1409	62-11419-00	86-04301-10	2.a 2.b	3.b	4	5.b	6.b	7.d	9.b	8	10.b	11.b	12	13.b	14.d	15.b
69RG15-130P-06	RG1406	62-11292-00	86-04301-05	2.a 2.b	3.a	4	5.b	6.a	7.a	9.a	8	10.b	11.a	12	13.c	14.a	15.c
	RG1407	62-11429-00	86-04301-05	2.a 2.b	3.a	4	5.b	6.a	7.a	9.a	8	10.b	11.a	12	13.d	14.a	15.c
	RG1412	62-11292-00	86-04301-05	2.a 2.b	3.a	4	5.b	6.b	7.a	9.a	8	10.b	11.a	12	13.c	14.a	15.c
	RG1413	62-11429-00	86-04301-05	2.a 2.b	3.a	4	5.b	6.b	7.a	9.a	8	10.b	11.a	12	13.d	14.a	15.c
69RG15-130P-07	RG1402	62-11287-00	86-04301-05	2.a 2.b	3.a	4	5.b	6.a	7.c	9.a	8	10.b	11.a	12	13.c	14.a	15.a
	RG1408	62-11287-00	86-04301-05	2.a 2.b	3.a	4	5.b	6.b	7.c	9.a	8	10.b	11.a	12	13.c	14.a	15.a
69RG15-130W-05	RG1404	62-11292-00	86-04301-18	2.a 2.b	3.c	4	5.b	6.a	7.a	9.a	8	10.b	11.a	12	13.c	14.a	15.a
	RG1410	62-11292-00	86-04301-18	2.a 2.b	3.c	4	5.b	6.b	7.a	9.a	8	10.b	11.a	12	13.c	14.a	15.a

MODEL CHART (Continued)

Model Number	PID Number	Schematic/ Wiring Diagram Decals	Fuel Tank Assembly Service Part Number	Undrive	Unit Mounting	Coolant System	Fuel System	Air Filter	Control Box	Voltage	Battery Charger	Battery	Exhaust System	Labels	Skins Option	Receptacle	Wire Harness
1500 Series Dual Speed																	
69RG15-130C-08	RG1514	62-10144-61	86-04301-21	2.a 2.b	3.d	4	5.c	6.a	7.b	9.a	8	10.b	11.b	12	13.b	14.g	15.a
	RG1515	62-11584-00	86-04301-21	2.a 2.b	3.d	4	5.c	6.a	7.f	9.a	8	10.b	11.a	12	13.a	14.g	15.a
69RG15-130C-08	RG1520	62-11584-00	86-04301-21	2.a 2.b	3.b	4	5.c	6.a	7.f	9.a	8	10.b	11.a	12	13.c	14.i	15.a
69RG15-130P-07	RG1502	62-11442-00	86-04301-05	2.a 2.b	3.a	4	5.b	6.b	7.b	9.a	8	10.b	11.a	12	13.h	14.j	15.a
69RG15-130W-05	RG1504	62-11442-00	86-04301-05	2.a 2.b	3.d	4	5.b	6.a	7.b	9.a	8	10.b	11.a	12	13.c	14.f	15.a
69RG15-130W-08	RG1518	62-11584-00	86-04301-05	2.a 2.b	3.d	4	5.b	6.a	7.f	9.a	8	10.a	11.a	12	13.h	14.i	15.a
69RG15-130P-08	RG1519	62-11584-00	86-04301-05	2.a 2.b	3.d	4	5.c	6.a	7.f	9.a	8	10.a	11.a	12	13.e	14.i	15.a
69RG15-130C-05	RG1521	62-11442-00	86-04301-05	2.a 2.b	3.b	4	5.b	6.b	7.b	9.a	8	10.b	11.a	12	13.c	14.h	15.a
1600 Series Dual Speed Provision																	
69RG15-130W-05	RG1604	62-11442-00	86-04301-05	2.a 2.b	3.a	4	5.b	6.a	7.a	9.a	8	10.b	11.a	12	13.c	14.f	15.a
	RG1616	62-11442-00	86-04301-05	2.a 2.b	3.a	4	5.b	6.b	7.a	9.a	8	10.b	11.a	12	13.b	14.f	15.a
	RG1624	62-11442-00	86-04301-05	2.a 2.b	3.a	4	5.b	6.b	7.a	9.a	8	10.b	11.a	12	13.h	14.j	15.a
69RG15-130C-05	RG1621	62-11442-00	86-04301-05	2.a 2.b	3.b	4	5.b	6.b	7.a	9.a	8	10.b	11.a	12	13.h	14.h	15.a
	RG1623	62-11442-00	86-04301-05	2.a 2.b	3.b	4	5.b	6.b	7.a	9.a	8	10.b	11.a	12	13.h	14.j	15.a
69RG15-130P-06	RG1613	62-11445-00	86-04301-05	2.a 2.b	3.b	4	5.b	6.b	7.a	9.a	8	10.b	11.a	12	13.d	14.h	15.a

1 RG GENSET CONFIGURATION

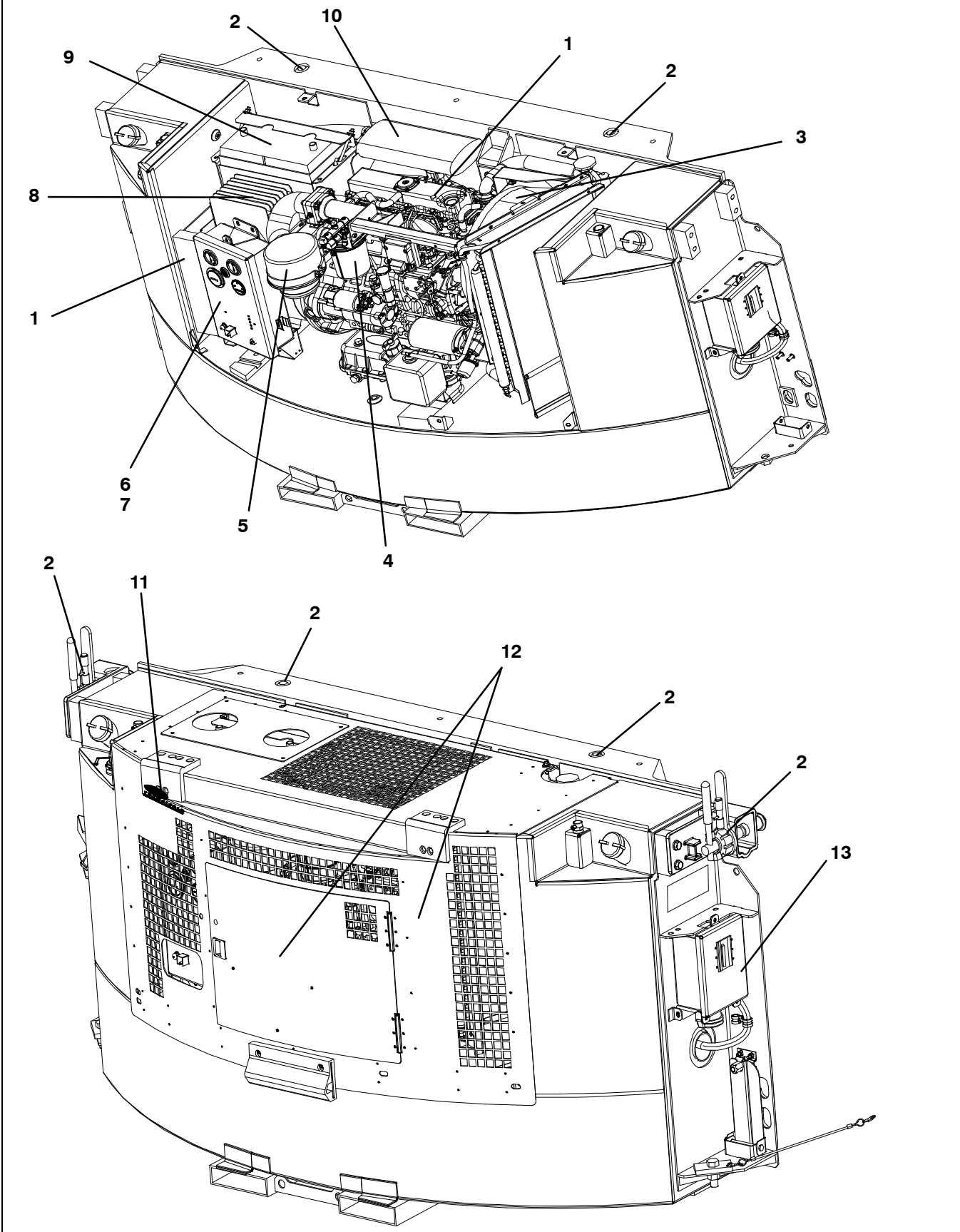

1 RG GENSET CONFIGURATION (Continued)		
Item	Section Number	Area Description
1	Refer to Section 2	Unidrive
2	Refer to Section 3	Unit Mounting
3	Refer to Section 4	Coolant System
4	Refer to Section 5	Fuel System
5	Refer to Section 6	Air Filter
6	Refer to Section 7	Control Boxes
7	Refer to Section 9	Voltage
8	Refer to Section 8	Battery Charger
9	Refer to Section 10	Battery
10	Refer to Section 11	Exhaust System
11	Refer to Section 12	Labels
12	Refer to Section 13	Skins Options
13	Refer to Section 14	Receptacles
NS	Refer to Section 15	Wire Harness

2 UNIDRIVE

2.a UNIDRIVE ASSEMBLY

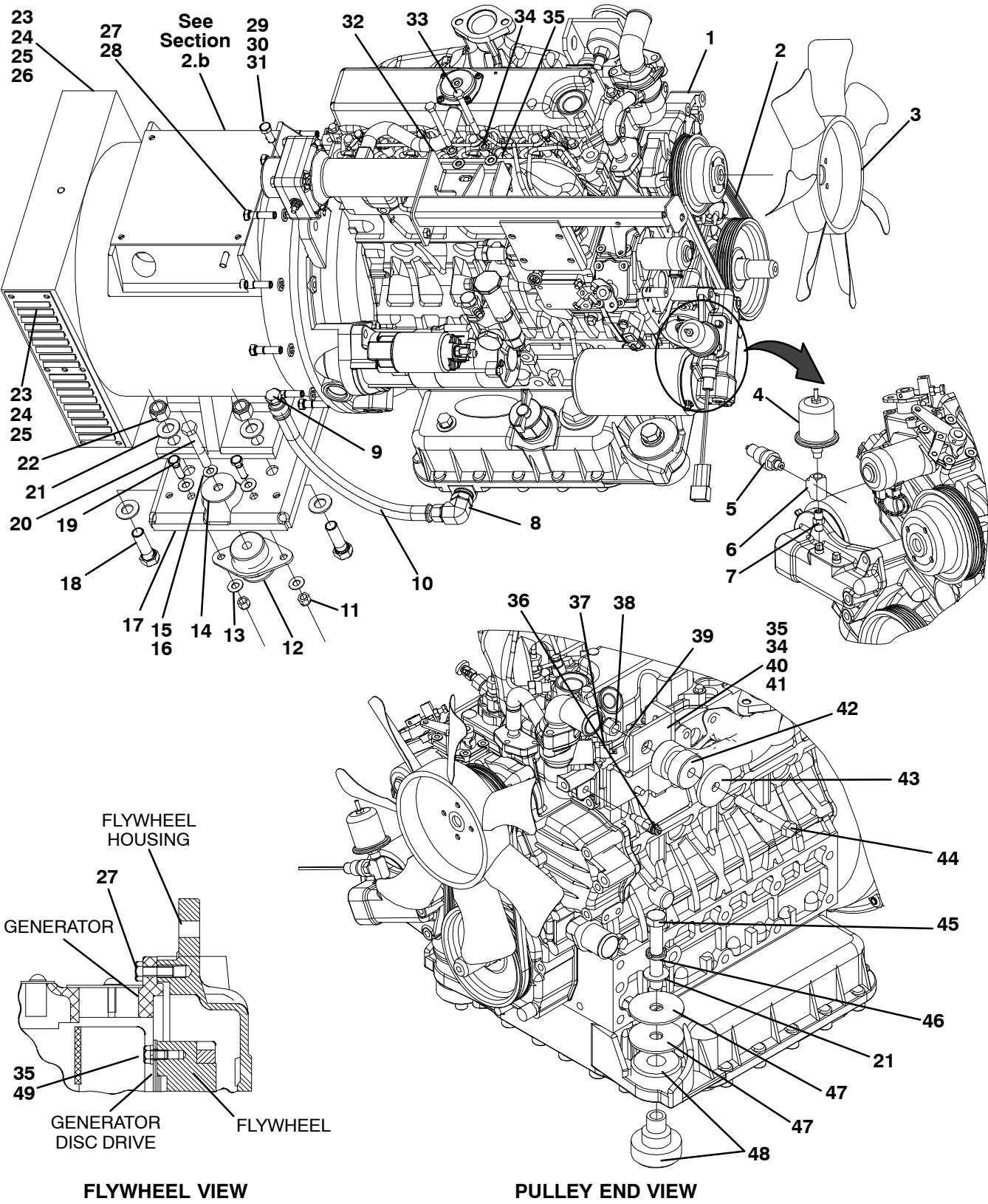

2.a UNIDRIVE ASSEMBLY (Continued)			
Item	Part Number	Description	Qty
1	26-00128-01	Engine, Kubota Tier 4i	1
2	50-60330-03	V-Belt, Poly	1
3	34-00945-06	Washer, Lock M6 Spring	4
4	66U1-2823-3	Sender, Oil Pressure	1
5	12-00592-00	Switch, Pressure Oil	1
6	40-00107-01	Tee 1/8	1
7	40-00067-01	Nipple, Hex 1/8 x 1/8	1
8	40-00566-00	Elbow, 90 Degree Street	1
9	40-00043-05	Plug 1/2 Inch Flare	1
10	66CH1-123-100	Hose Assembly, 12.00 Inches Long	1
11	34-00667-13	Nut, Self Lock 3/8-16	4
12	73-00175-01	Shockmount, Generator	2
13	34-00829-13	Washer, Plain 3/8	8
14	34-00890-09	Washer, Flat, 0.515 ID X 2.00 OD	2
15	34-00829-15	Washer, Plain, 1/2	2
16	66U1-5331-9	Washer, Lock 1/2 Spring	2
17	86-04182-00	Base, Mounting Generator	1
18	34-00804-18	Screw, Cap Hex Head 5/8-18 x 2.25 Inches Long	4
19	34-00807-10	Screw, Cap Hex Head 3/8-16 x 1.25 Inches Long	4
20	34-00833-24	Screw, Cap Hex Head 1/2-13 x 3.00 Inches Long	2
21	66U1-5321-9	Washer, Plain 5/8 N Type A	10
22	34-00795-17	Nut, Self Lock 5/8-18	4
23	34-00655-04	Screw, Cap Hex Head 1/4-20 x 0.50 Inch Long	10
24	AU11JR171	Washer, Lock 1/4 Spring	10
25	34-00662-11	Washer, Plain 1/4	10
26	68-12166-00	Plate	1
27	34-00807-12	Screw, Cap Hex Head 3/8-16 x 1.50 Inches Long	12
28	AU11JR241	Washer, Lock 3/8 Spring	12
29	68-12174-00	Strap	1
30	66U1-5321-5	Washer, Plain 3/8 N Type A	1
31	34-00807-04	Screw, Cap Hex Head 3/8-16 x 0.62 Inch Long	1
32	86-04676-00	Bracket Assembly	1
33	34-01153-82	Bolt, Hex 8 mm x 16 mm	2
34	34-01146-08	Washer, Lock M8 Spring	4
35	34-01151-08	Washer, Flat M8	10
36	12-00098-04	Sending Unit, Water Temp	1
37	10-00158-02	Switch, Safety 1/2 Inch Water Temperature	1
38	34-00667-15	Nut, Self Lock 1/2-13	1
39	66U1-5321-11	Washer, Plain 1/2 N Type A	1
40	86-04674-00	Weld Assembly	1
41	34-01145-06	Nut, Hex M8	2
42	73-00305-00	Shockmount	1
43	34-00890-08	Washer	1
44	AA06BZ300	Screw, Cap Hex Head 1/2-13 x 3.25	1
45	66U1-5361-36	Screw, Cap Hex Head 5/8-11 x 4.00 Inches Long	2
46	66U1-5331-8	Washer, Lock 5/8 Spring	2
47	34-06060-01	Washer, Snubbing	4
48	73-00198-00	Shockmount	2
49	34-01153-15	Screw, Cap Hex Head 8 mm x 15 mm	6

2.b GENERATOR - MAIN ALTERNATOR

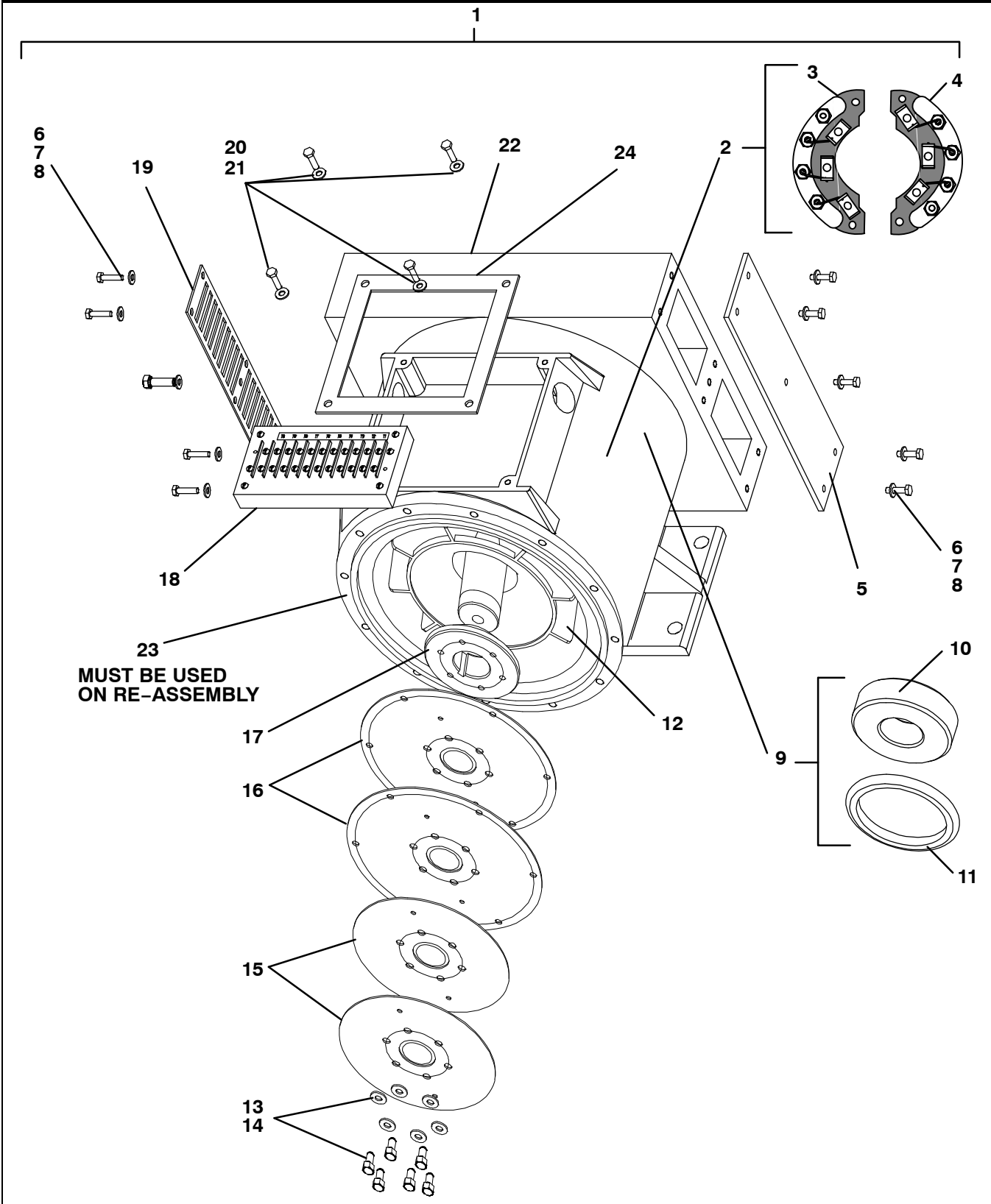

2.b GENERATOR – MAIN ALTERNATOR (Continued)

Item	Part Number	Description	Qty
1	54-00576-03	Generator, 15 KW, with Hub/Key way – Includes:	1
2	22-50206-00	Rectifier Assembly – Includes:	1
3	NSS	Diode Assembly, Forward (With Red Stud)	1
4	NSS	Diode Assembly, Reverse (With Black Stud)	1
5	54-50083-00	Side Cover	1
6	34-00655-04	Bolt, Hex Head, 1/4-20 x 1/2 Lg – SST	2
7	AU11JR171	Washer, Lock, 1/4-20 – Steel Plated	10
8	34-00662-12	Washer, Flat, 1/4-20 x 11/2 – SST	2
9	76-50110-00	Bearing Kit – Includes:	1
10	04-50012-00	Bearing	1
11	42-50010-00	O-Ring	1
12	54-50084-00	Fan, One-Piece, Die Cast	1
13	34-00304-08	Bolt, Hex Head Socket, 3/8-24 x 1-1/4 Lg – SST	6
14	34-06278-00	Washer, Belleville – 3/8	6
15	68-14699-01	Disc, Pilot, Generator	2
16	68-14698-01	Disc, Drive, Generator	2
17	48-00392-00	Hub, Generator	1
18	54-50085-00	Terminal Block, 11 Poles	1
19	54-50082-00	Air Baffle	1
20	34-00655-06	Bolt, Hex Head, 1/4-20 x 3/4 Lg – SST	4
21	66U1-5321-3	Washer, Flat 1/4 – SST	4
22	54-50039-00	End Cover	1
23	02-00083-00	Anti-Corrosion Coating (1 Ounce Syringe)	1
24	42-00348-00	Gasket	1

3 UNIT MOUNTING

3.a, 3.b, 3.c, 3.d UNIT MOUNTING

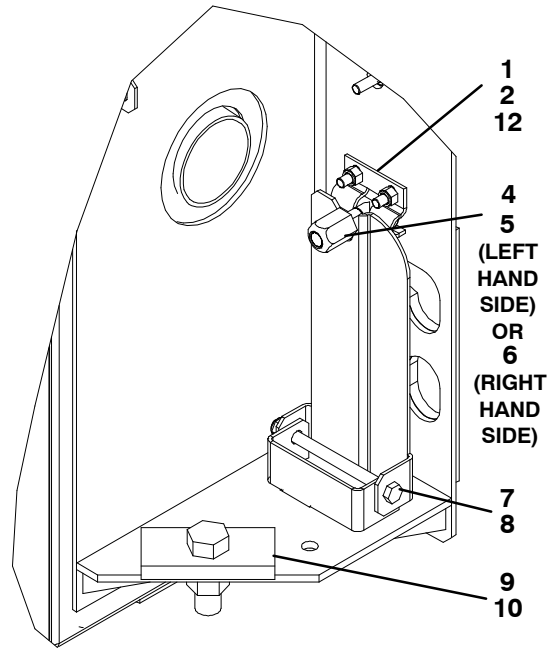
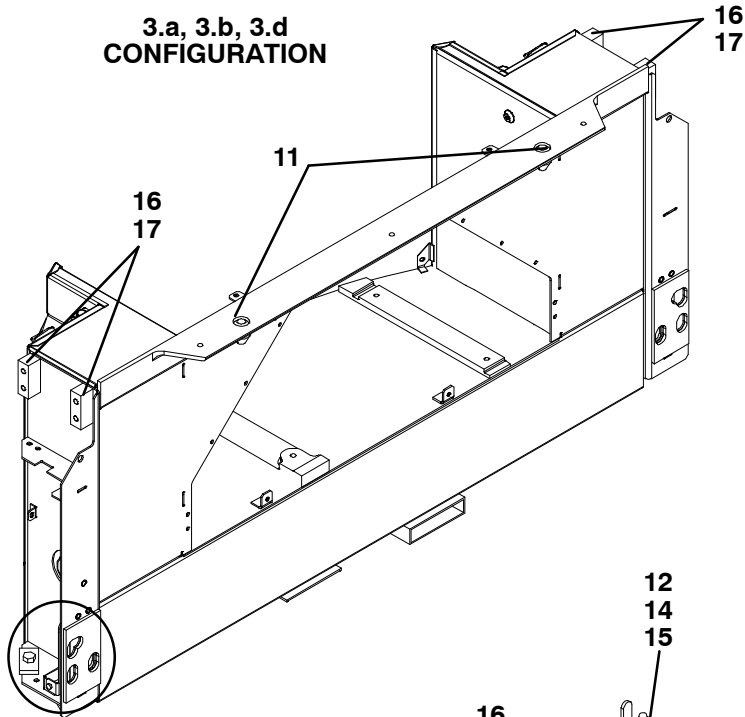

DETAIL A:
3.a, 3.b, 3.c

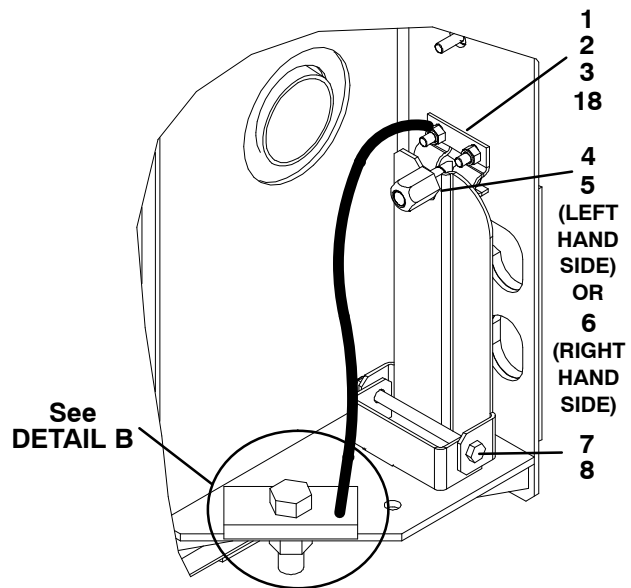
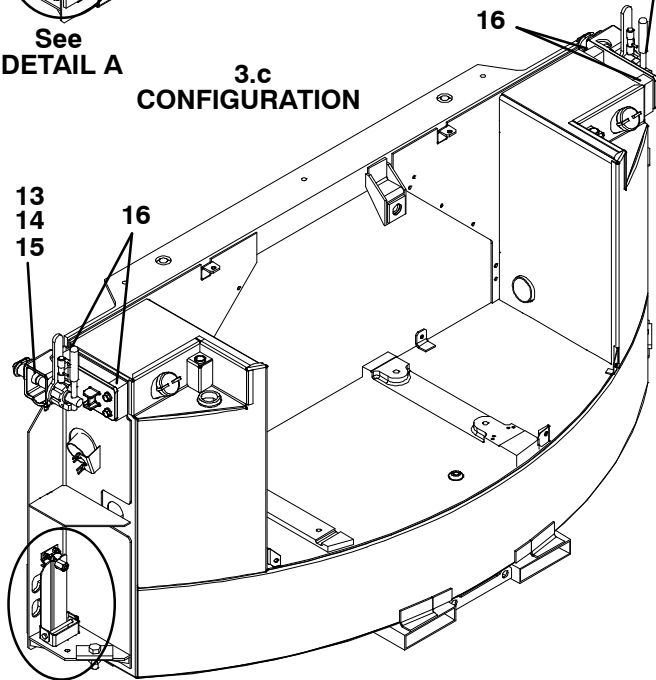

DETAIL A:
3.d ONLY

See
DETAIL A

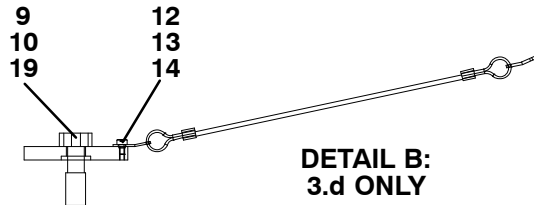

DETAIL B:
3.d ONLY

3 UNIT MOUNTING (Continued)			
Item	Part Number	Description	Qty
COMMON PARTS FOR OPTIONS 3.a THROUGH 3.d			
1	68-12997-00	Bracket, Mounting, T-Bolt, Painted – See NOTE	2
2	34-00667-12	Nut, Self Locking, 5/16-18, SST	4
3	34-06201-00	Bolt, T-Head, 1/2-13 x 2.75 Inches Long, SST	2
4	34-06207-00	Knob, Hex, 1/2-13, Brass	2
5	68-12998-01	Retainer, Lower Mounting Bolt, Left Side – See NOTE	1
6	68-12998-00	Retainer, Lower Mounting Bolt, Right Side – See NOTE	1
7	34-00667-13	Nut, Self Locking, 3/8-16, SST	2
8	34-06200-00	Screw, Cap Hex Head, 3/8-16 x 4.88 Inches Long, SST	2
3.a UNIT MOUNTING – PIN MOUNT (INCLUDES COMMON PARTS AND ITEMS BELOW)			
9	34-06149-02	Screw, Cap Hex Head, 3/4-10 x 2.25 Inches Long	2
10	68-12996-01	Plate, Spacer, Painted – See NOTE	2
11	69GC15-1602	Pin, Unit Mounting	2
3.b UNIT MOUNTING – CLAMP MOUNT (INCLUDES COMMON PARTS AND ITEMS BELOW)			
9	34-06149-02	Screw, Cap Hex Head, 3/4-10 x 2.25 Inches Long	2
11	68-12996-01	Plate, Spacer, Painted – See NOTE	2
12	44-00362-02	Clamp, Unit Mounting, Clip-On, Right Side (Cast)	1
13	44-00362-03	Clamp, Unit Mounting, Clip-On, Left Side (Cast)	1
14	34-06170-08	Screw, Cap Socket Head, 5/8-11 x 1.75 Inches Long	8
15	66U1-5331-8	Washer, Split Lock, 5/8, SST	8
16	48-00309-00	Mounting Block	4
3.c UNIT MOUNTING – PIN MOUNT WITH CLAMP PROVISION (INCLUDES COMMON PARTS AND ITEMS BELOW)			
9	34-06149-02	Screw, Cap Hex Head, 3/4-10 x 2.25 Inches Long	2
10	68-12996-01	Plate, Spacer, Painted – See NOTE	2
11	69GC15-1602	Pin, Unit Mounting	2
16	48-00309-00	Mounting Block	4
17	58-00024-01	Caplug	8
3.d UNIT MOUNTING – PIN MOUNT WITH TETHER (INCLUDES COMMON PARTS AND ITEMS BELOW)			
9	34-06149-03	Screw, Cap Hex Head, 3/4-10 x 2.25 Inches Long	2
10	48-00354-00	Spacer, Plate, SST	2
11	69GC15-1602	Pin, Unit Mounting	2
12	44-00402-00	Tether Assembly	2
13	34-06229-00	Bolt, Shoulder, Socket Head, #10-32 x 0.250 Inch Long, SST	2
16	48-00309-00	Mounting Block	4
17	58-00024-01	Caplug	8
18	66U1-5321-4	Washer, Plain, Type A, 5/16 N, SST	4
19	34-06205-00	Washer, Retaining, SST	2

NOTE: See page ii for painted parts color system.

4 COOLANT SYSTEM

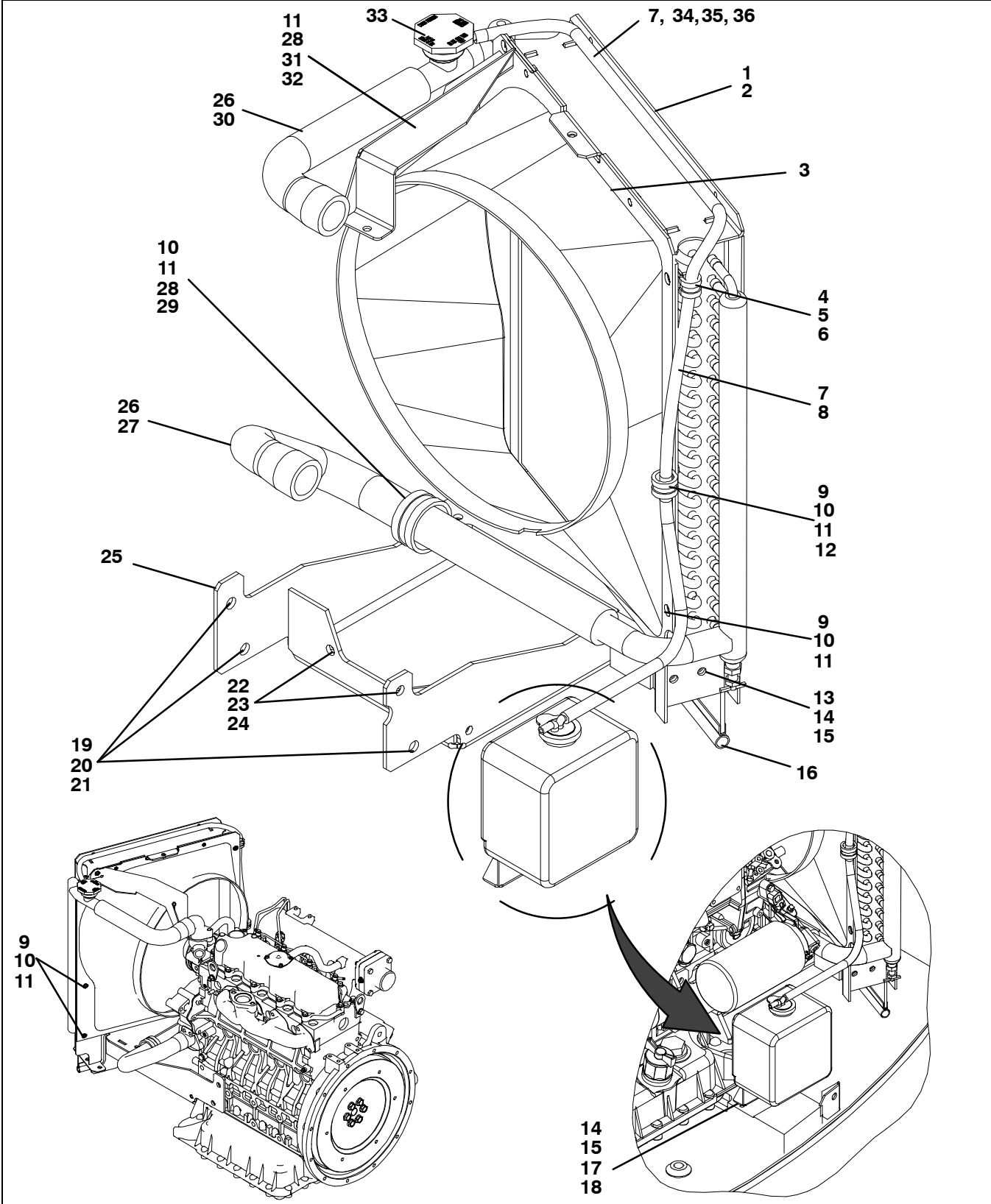

4 COOLANT SYSTEM (Continued)			
Item	Part Number	Description	Qty
1	81-04054-00	Radiator Assembly - Includes:	1
2	40-00117-01	Valve, Drain Cock, 1/4 Inch MPT, Brass	1
3	58-04765-00	Venturi	1
4	34-00667-11	Nut, Self Locking, 1/4-20, SST	1
5	44-00102-52	Clamp, Hose, Cushioned, 0.56 Diameter, SST	1
6	34-00655-08	Screw, Cap Hex Head, 1/4-20 x 1.00 Inch Long, SST	1
7	66U1-3882	Wire Tie, Self-Locking, 7.00 Inches, Black	4
8	58-00848-00	Tubing, Split, Corrugated, 1/2 Inch ID x 25 Feet Long	1
9	66U1-5361-25	Screw, Cap Hex Head, 1/4-20 x 0.75 Inch Long, SST	4
10	69NT35-2692-1	Washer, Fender, 1/4, SST	5
11	AU11JR171	Washer, Split Lock, 1/4, SST	6
12	44-00102-54	Clamp, Hose, Cushioned, 0.75 Diameter, SST	1
13	66U1-5361-39	Screw, Cap Hex Head, 5/16-18 x 1.00 Inch Long, SST	5
14	34-00663-12	Washer, Split Lock, 5/16, SST	7
15	66U1-5321-4	Washer, Plain, Type A, 5/16N, SST	7
16	42-00264-09	Seal, Trim, Black, 14.50 Inches Long	1
17	86-04470-00	Bracket Assembly, Coolant Bottle, Painted	1
18	66U1-5361-6	Screw, Cap Hex Head, 5/16-18 x 0.75 Inch Long, SST	2
19	34-01155-25	Screw, Cap Hex Head, M12 x 25.00 MM Long, SST	3
20	34-01151-12	Washer, Flat, M12, SST	3
21	34-01146-12	Washer, Split Lock, M12, SST	3
22	34-01154-25	Screw, Cap Hex Head, M10 x 25.00 MM Long, SST	3
23	34-01151-10	Washer, Flat, M10, SST	3
24	34-01146-10	Washer, Split Lock, M10, SST	3
25	86-04288-01	Support Assembly, Radiator, Painted	1
26	KA69JM824	Clamp, Hose, Worm Type, Range: 1.06 to 2.00, SST	4
27	58-04268-00	Hose, Formed, Inlet, 1-1/8 ID	1
28	66U1-5361-14	Screw, Cap Hex Head, 1/4-20 x 0.88 Inch Long, SST	2
29	44-00102-61	Clamp, Hose, Cushioned, 1.56 Diameter, SST	1
30	58-04267-00	Hose, Formed, Outlet, 1-1/8 ID	1
31	86-04675-00	Support Assembly, Radiator, Painted	1
32	66U1-5321-7	Washer, Plain, Type A, 1/4W, SST	1
33	30-00397-00	Cap, Radiator, 16 Lbs.	1
34	58-04184-04	Hose, Fuel, 1/4 ID x 42.00 Inches Long	1
35	44-00388-00	Clamp, Hose, Flat Band, 0.50 ID	2
36	58-04316-00	Base, Push Mount, Cable Tie	2

5 FUEL SYSTEM

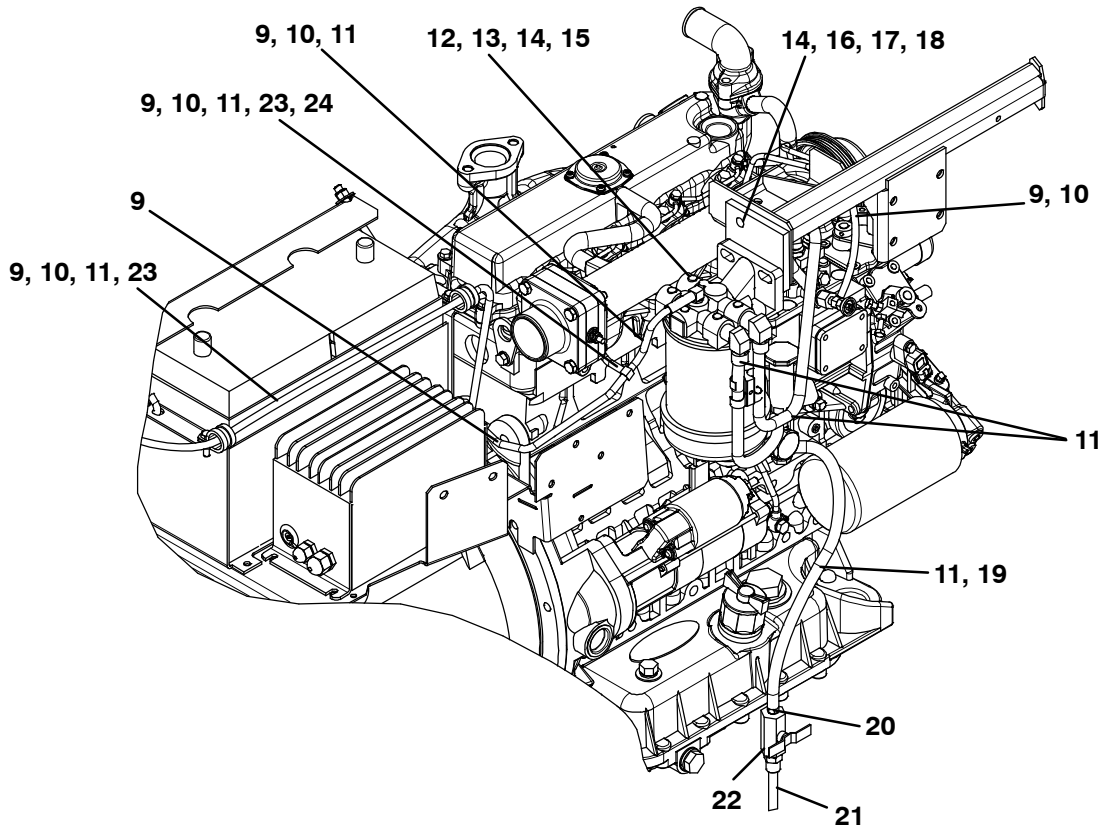
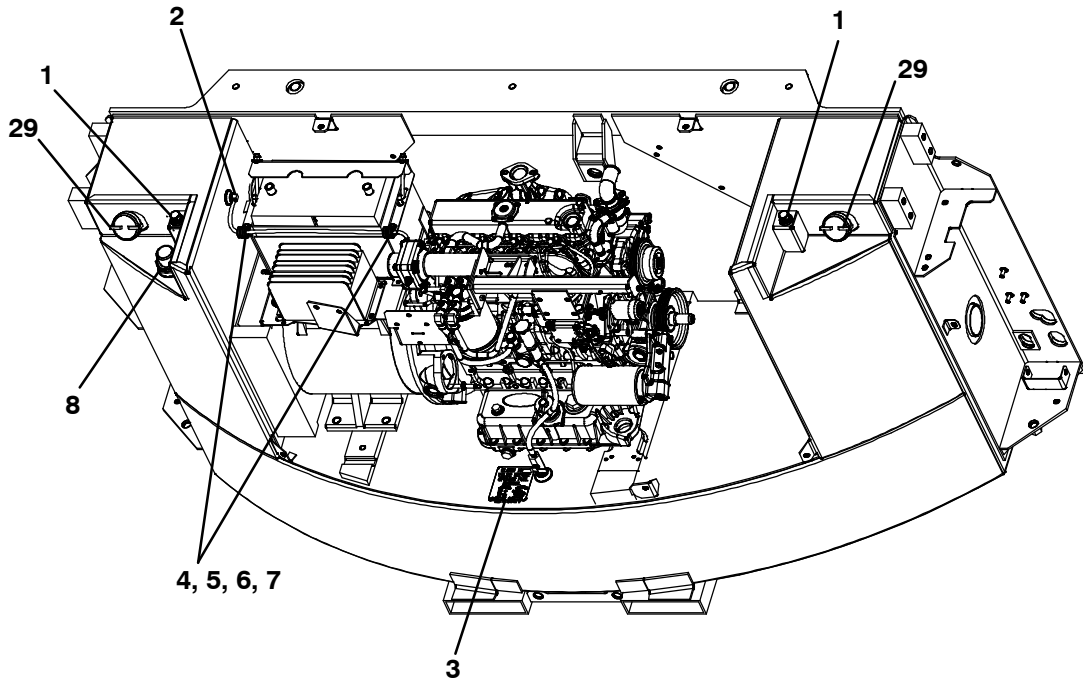

5 FUEL SYSTEM (Continued)

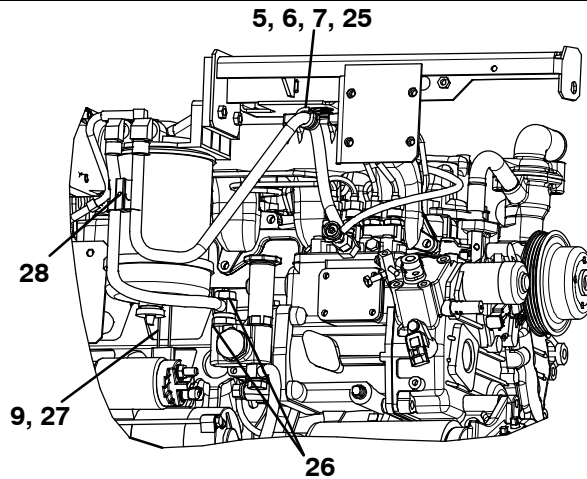

FUEL SYSTEM COMMON PARTS

Item	Part Number	Description	Qty
1	40-00697-00	Vent Fuel Tank	2
2	40-00213-00	Fitting, Hose, bulk (90Deg 1/4Idx1/8Mpt)	1
3	69GC-15-3212	Label Fuel Shutoff	1
4	44-00102-54	Clamp, Cushioned	2
5	34-06212-12	Washer, Plain 1/4	3
6	34-00663-11	Washer, Lock 1/4 Spring	3
7	34-00655-08	Screw, Cap Hex Head 1/4-20 X 1.00	3
8	12-01098-03	Gauge, Fuel	1
9	58-00079-02	Sta-Strap	12
10	58-00848-00	Tube, Slit, 1/2 I.D. bulk	A/R
11	44-00045-25	Clamp	12
12	30-01104-13	Filter Assembly	1
13	66U1-5361-38	Bolt, Mach Hex Head 5/16-18 X 1.50	2
14	66U1-5321-4	Washer, Plain 5/16	4
15	34-00663-12	Washer, Lock 5/16 Spring	2
16	48-00449-00	Spacer	1
17	34-00667-12	Nut, Self Lock	1
18	34-00792-10	Screw, Cap Hex Head 5/16-18 X 1.25	1
19	58-00658-00	Hose, Fuel, 5/16 I.D. bulk	A/R
20	40-00420-01	Fitting	1
21	81-04100-00	Tube, Pickup	1
22	40-00469-00	Valve, Fuel Shutoff	1
23	58-00659-00	Hose, Fuel, 3/16 I.D. bulk	A/R
24	40-01156-00	Tee, Male Branch	1
25	44-00102-52	Clamp, Cushioned	1
26	42-01133-00	Seal	2
27	58-00858-00	Tube, Slit, 1/4 I.D. bulk	A/R
28	44-00317-00	Clip 1/2 To 5/8 Tee	1

5 FUEL SYSTEM (Continued)

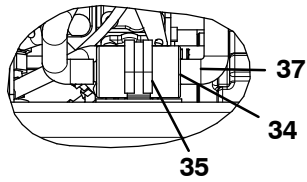

Fuel Warmer Top View

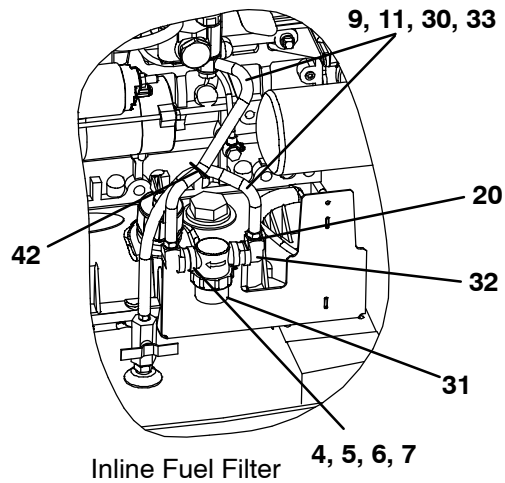
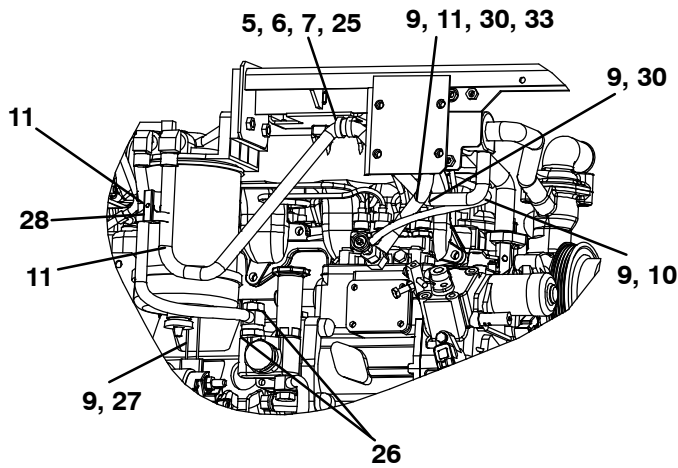
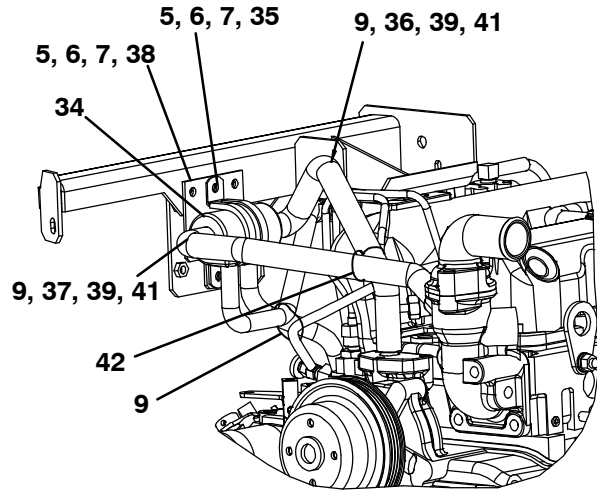

Inline Fuel Filter

FUEL SYSTEM - STANDARD WITH INLINE FILTER (Includes Common Parts)

Item	Part Number	Description	Qty
29	44-00046-13	Cap Assembly	2
30	58-00849-00	Tube, Slit, 5/8 I.D. bulk	A/R
31	30-00373-02	Filter	1
32	40-00708-00	Fitting, 90 1/2"	2
33	58-00658-00	Hose, Fuel, 5/16 I.D. bulk	A/R

5 FUEL SYSTEM – STANDARD WITH FUEL WARMER AND INLINE FILTER (Includes Common Parts)			
Item	Part Number	Description	Qty
29	44-00046-13	Cap Assembly	2
30	58-00849-00	Tube, Slit, 5/8 I.D. bulk	A/R
34	30-00344-04	Fuel Warmer	1
35	44-00459-00	Clamp, Tube	1
36	58-04840-00	Hose, Formed Fuel Warmer	1
37	58-04839-00	Hose, Formed Fuel Warmer	1
38	68-15898-00	Bracket	1
39	44-00045-02	Clamp, Hose	4
40	58-00658-00	Hose, Fuel, 5/16 I.D. bulk	A/R
41	58-00850-00	Tube, Slit, 1" O.D. bulk	A/R
42	58-00969-00	Wire Tie	2
43	30-00373-02	Filter	1
44	40-00708-00	Fitting, 90 1/2	2
FUEL SYSTEM – STANDARD WITH SINGLE GAS CAP AND FUEL WARMER (Includes Common Parts)			
29	44-00046-14	Cap Assembly	1
30	58-00849-00	Tube, Slit, 5/8 I.D. bulk	A/R
34	30-00344-04	Fuel Warmer Diesel	1
35	44-00459-00	Clamp, Tube	1
36	58-04840-00	Hose, Formed Fuel Warmer	1
37	58-04839-00	Hose, Formed Fuel Warmer	1
38	68-15898-00	Bracket	1
39	44-00045-02	Clamp, Hose	4
40	58-00658-00	Hose, Fuel, 5/16 I.D. bulk	A/R
41	58-00850-00	Tube, Slit, 1" O.D. bulk	A/R
42	58-00969-00	Wire Tie	1
5.a FUEL SYSTEM – 102 GAL CAPACITY WITH ALUMINUM CAP (Includes Common Parts)			
8	12-01098-05	Gauge, Fuel, 1-1/2 MPT x 34.38 Inches Long	1
29	44-00046-13	Cap Assembly, Fuel Tank, Non-Vented, Aluminum	1
5.b FUEL SYSTEM – 130 GAL CAPACITY WITH ALUMINUM CAP (Includes Common Parts)			
8	12-01098-03	Gauge, Fuel, 1-1/2 MPT x 34.38 Inches Long	1
29	44-00046-13	Cap Assembly, Fuel Tank, Non-Vented, Aluminum	2
5.c FUEL SYSTEM – 130 GAL CAPACITY WITH BRASS CAP (Includes Common Parts)			
8	12-01098-03	Gauge, Fuel, 1-1/2 MPT x 34.38 Inches Long	1
29	44-00046-14	Cap Assembly, Fuel Tank, Non-Vented, Brass	2
5.d FUEL SYSTEM – 130 GAL CAPACITY, TIR (Includes Common Parts)			
8	12-01098-07	Gauge, Fuel, 1-1/2 MPT x 34.38 Inches Long, With 0.094 Thru Hole	1
29	44-00046-14	Cap Assembly, Fuel Tank, Non-Vented, Brass	2
5.e FUEL SYSTEM – 130 GAL CAPACITY W/DUAL FUNCTION FUEL GAUGE (Includes Common Parts)			
8	12-01098-08	Gauge, Fuel, 1-1/2 MPT x 34.38 Inches Long	1
29	44-00046-13	Cap Assembly, Fuel Tank, Non-Vented, Aluminum	2

6 AIR FILTERS

6.a OIL BATH AIR FILTER

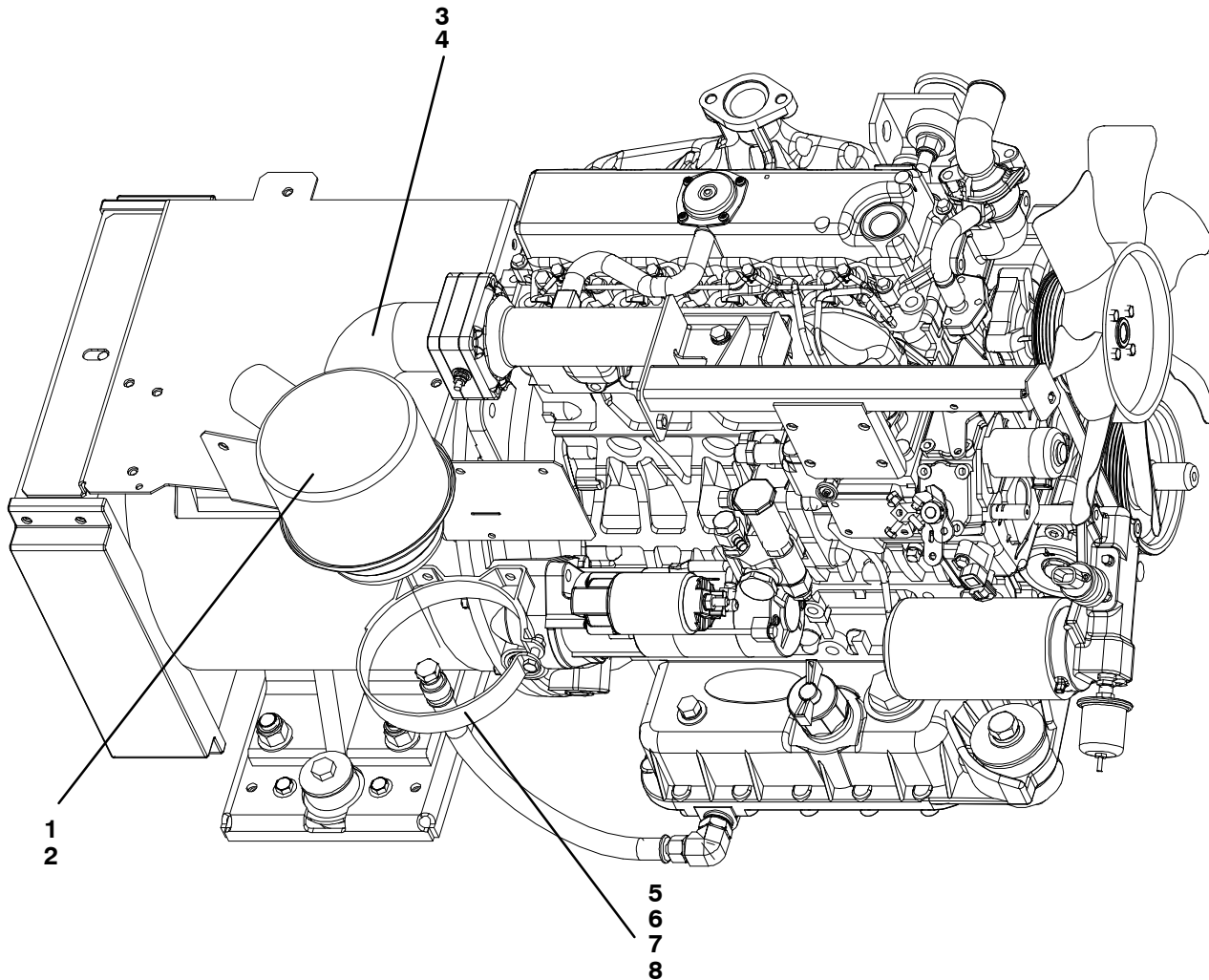

Item	Part Number	Description	Qty
1	30-00473-03	Air Cleaner Assembly, Oil Bath - Includes:	1
2	30-00473-20	Gasket	1
3	58-04766-00	Hose, Formed, Air Cleaner	1
4	KA69JM840	Clamp, Hose, Worm Type, Range: 1.13 to 3.00 Inches	2
5	44-00447-01	Bracket, Mounting, Air Cleaner	1
6	66U1-5361-25	Screw, Cap Hex Head, 1/4-20 x 0.75 Inch Long, SST	2
7	34-00667-11	Nut, Self Locking, 1/4-20, SST	2
8	66U1-5321-3	Washer, Plain, Type A, 1/4, SST	2

6.b DRY ELEMENT AIR FILTER

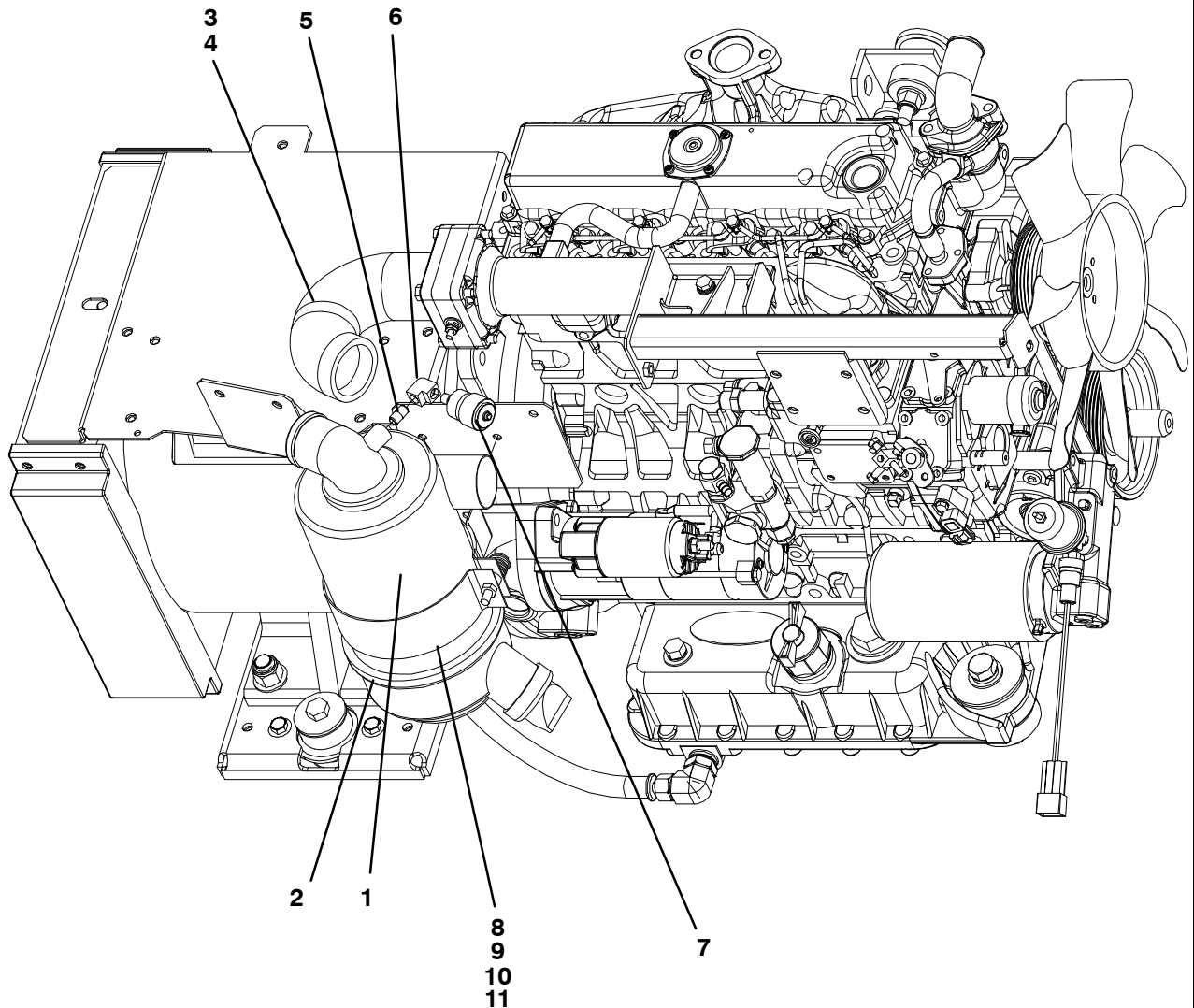

Item	Part Number	Description	Qty
1	30-00426-05	Air Cleaner, Dry Element – Includes:	1
2	30-00426-25	Filter, Air Cleaner	1
3	58-04836-00	Hose, Air Cleaner	1
4	KA69JM840	Clamp, Hose, Worm Type, Range: 1.13 to 3.00 Inches	2
5	40-01176-52	Nipple, 1/8 x 1/8 FPT	1
6	40-00512-00	Elbow, Union, 1/8 x 1/8 FPT	1
7	30-00328-00	Indicator, Air Cleaner	1
8	44-00454-00	Bracket, Mounting, Air Cleaner	1
9	66U1-5361-25	Screw, Cap Hex Head, 1/4-20 x 0.75 Inch Long, SST	2
10	34-00667-11	Nut, Self Locking, 1/4-20, SST	2
11	66U1-5321-3	Washer, Plain, Type A, 1/4, SST	2

7 CONTROL BOXES

7.a, 7.b STANDARD CONTROL BOX, STANDARD CONTROL BOX WITH 2-SPEED

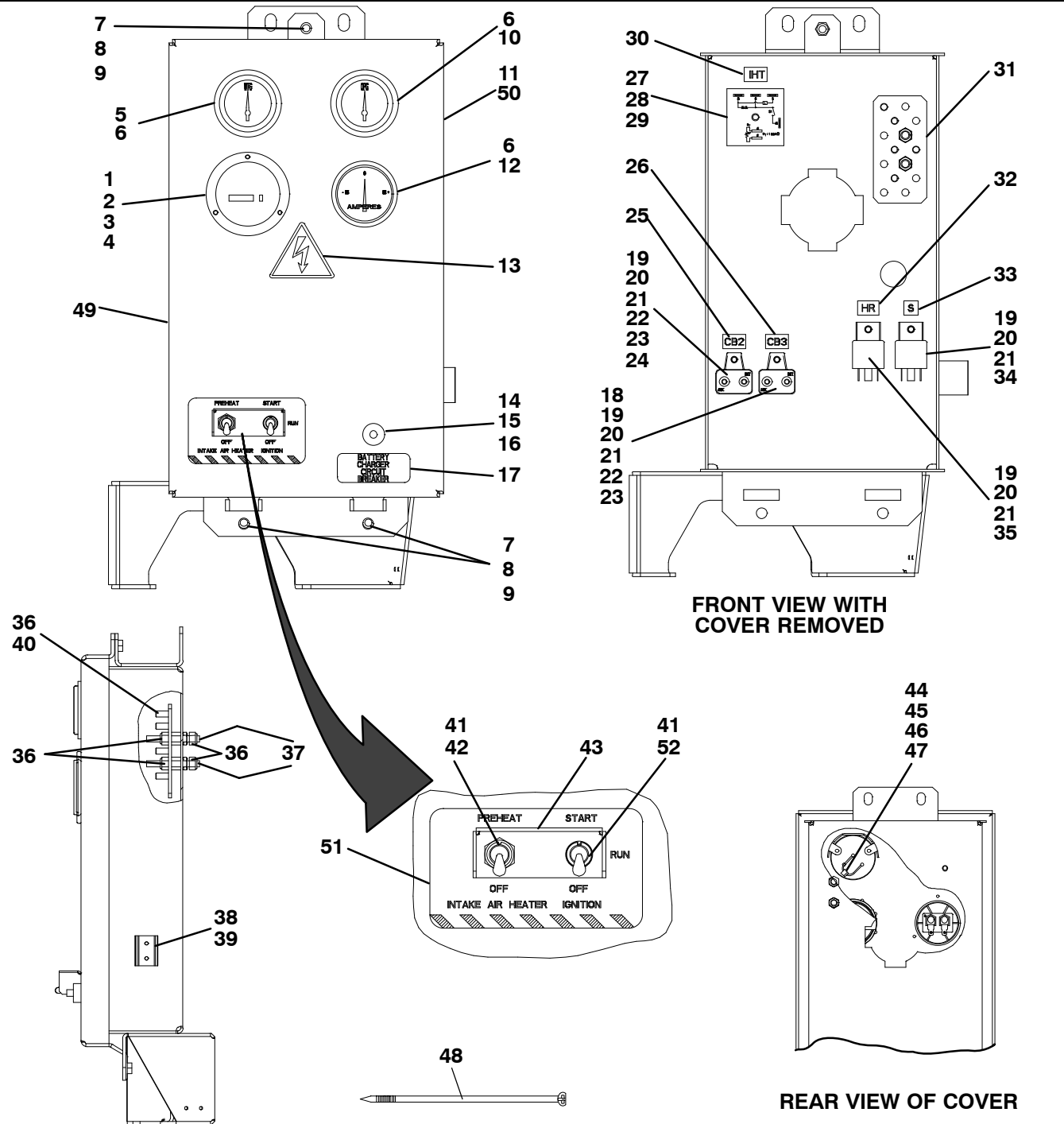

Item	Part Number	Description	Qty
COMMON PARTS – STANDARD CONTROL BOX AND 2-SPEED			
	91-00398-XX	Control Box Assembly, – See Sections 7.a or 7.b	1
1	10-00448-00	Meter, Hour (Operating Range: 10-80 VDC)	1
2	66U1-6651-15	Screw, Machine, Pan Head Slotted, #4-40 x 0.75 Long, SST.	3
3	34-00667-05	Nut, Self Locking, #4-40, SST	3
4	69GS4-1582-1	Gasket, Hour Meter	1
5	12-00097-03	Gauge, Water Temperature, 100-240 Degrees F, 12 VDC	1
6	KK71EW223	O-Ring	3
7	66U1-5321-3	Washer, Plain, Type A, 1/4, SST	3

COMMON PARTS – STANDARD CONTROL BOX AND 2–SPEED (Continued)			
Item	Part Number	Description	Qty
8	AU11JR171	Washer, Lock, 1/4, SST	3
9	66U1-5361-25	Screw, Hex Head, 1/4-20 x 0.75 Inch Long, SST	3
10	66U1-2823	Gauge, Oil Pressure, 0-100 PSI, 12 VDC	1
11	42-00341-00	Gasket, Control Box	1
12	22-00538-01SV	Ammeter Gauge Kit, +60/-60 Amp	1
13	62-03957-04	Label, HIGH VOLTAGE WARNING	1
14	10-00365-00	Circuit Breaker, 3 Amp	1
15	KK71GW007	O-Ring	1
16	10-00365-10	Boot, Circuit Breaker	1
17	69GC15-3812	Label, BATTERY CHARGER, CIRCUIT BREAKER	1
18	10-00171-12	Circuit Breaker, 30 Amp, 12 VDC	1
19	66U1-5331-4	Washer, Lock, #8, SST	7
20	34-00666-08	Nut, Hex, #8-32, SST	7
21	66U1-5321-2	Washer, Plain, Type A, #8, SST	7
22	66U1-5331-3	Washer, Lock, #10, SST	4
23	AT39QA132	Nut, Hex, #10-32, Brass	4
24	10-00171-13	Circuit Breaker, 50 Amp, 12 VDC	1
25	66U1-3662-21	Label, CB2	1
26	66CH1-1002-5	Label, CB3	1
27	10-00469-00	Time Delay	1
28	66U1-5321-8	Washer, Plain #10 Type A	1
29	34-00795-09	Nut, Self Lock 10-32	1
30	62-10530-25	Label, IHT	1
31	69NT41-982-2	Strap Assembly, Ground, Copper	1
32	66CH1-1002-38	Label, HR	1
33	66CH1-1002-132	Label, S	1
34	10-00286-03	Relay, SPST, Maximum 30 Amp	1
35	10-00328-00	Relay, 70 Amp	1
36	34-00667-11	Nut, Self Locking, 1/4-20, SST	9
37	66U1-9592-13	Standoff, Hex Head, 1/4-20 x 0.375 x 1/4-20 x 0.75 Long, SST	2
38	44-00094-09	Clip, Spring, "U" Type	1
39	34-00928-03	Rivet, Blind, 0.125 Diameter, Grip Range: 0.188 - 0.250, SST	2
40	58-04316-00	Base, Cable Tie, Push Mount, 0.250 Diameter Mounting Hole	5
41	66U1-9752	Seal, Bushing, 0.427/0.432	1
42	10-01129-19	Switch, Toggle, 4 Pole	1
43	68-12973-00	Bracket, Protector, Toggle Switches, Painted - See NOTE	1
44	22-01030-54	Diode Assembly, 6 Amp	1
45	22-02200-06	Washer, Plain #6	2
46	34-00667-07	Nut, Self Lock 6-32	2
47	66U1-8772	Diode Assembly, 6 Amp	1
48	66U1-3882	Wire Tie, Self-Locking, 7.00 Inches, Black (use for Wire Harness)	5
7.a STANDARD CONTROL BOX			
	91-00398-02	Control Box Assembly, Standard, Painted - Includes: - See NOTE	1
49	86-04231-07	Control Box	1
50	86-04165-04	Cover, Control Box, Standard, Painted	1
51	62-02669-01	Label, INTAKE HEATER AND IGNITION	1
52	10-01129-13	Switch, Toggle, 2 Pole, On/Off, With Hardware	1

NOTE: See page ii for painted parts color system.

7.b STANDARD CONTROL BOX WITH 2-SPEED

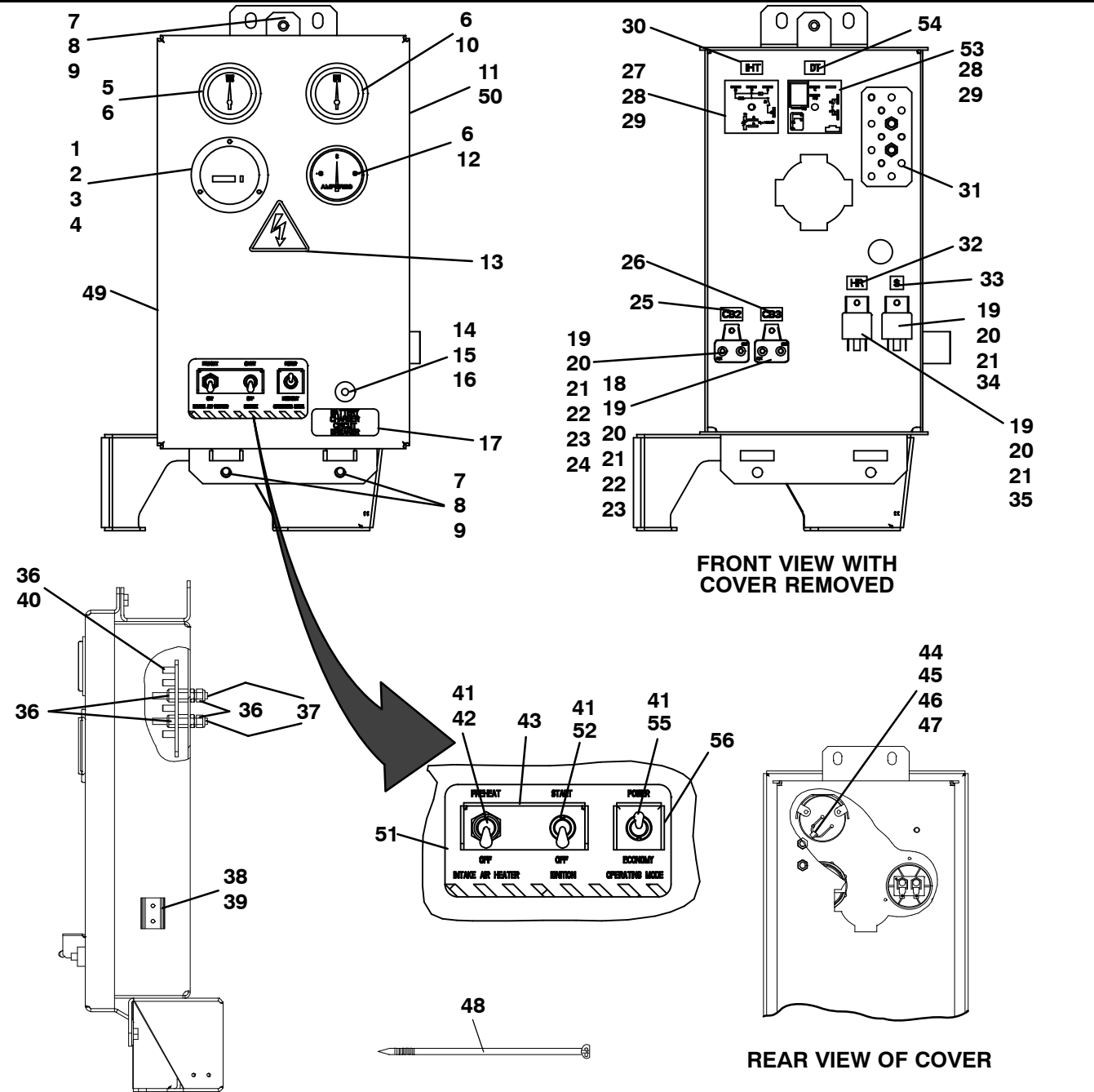

Item	Part Number	Description	Qty
	91-00398-05	Control Box Assembly, Standard, 2-Speed, Painted – Includes: – See NOTE	1
49	86-04231-10	Box Assembly, Welded	1
50	86-04165-08	Cover	1
51	62-02669-02	Label, Ih/Ign/2Spd Switch	1
52	10-01129-14	Switch, Toggle, On/On/On Momentary	1
53	10-00475-00	Timer, Time Delay, 2Hr	1
54	66CH1-1002-89	Label	1
55	10-01129-15	Switch, Toggle 1 Pole Off/On	1
56	69GC15-3542	Bracket	1

NOTE: See page ii for painted parts color system.

7.c, 7.d, 7.e, 7.g CONTROL BOXES WITH AUTO RESTART, TIME DELAY, 2-SPEED

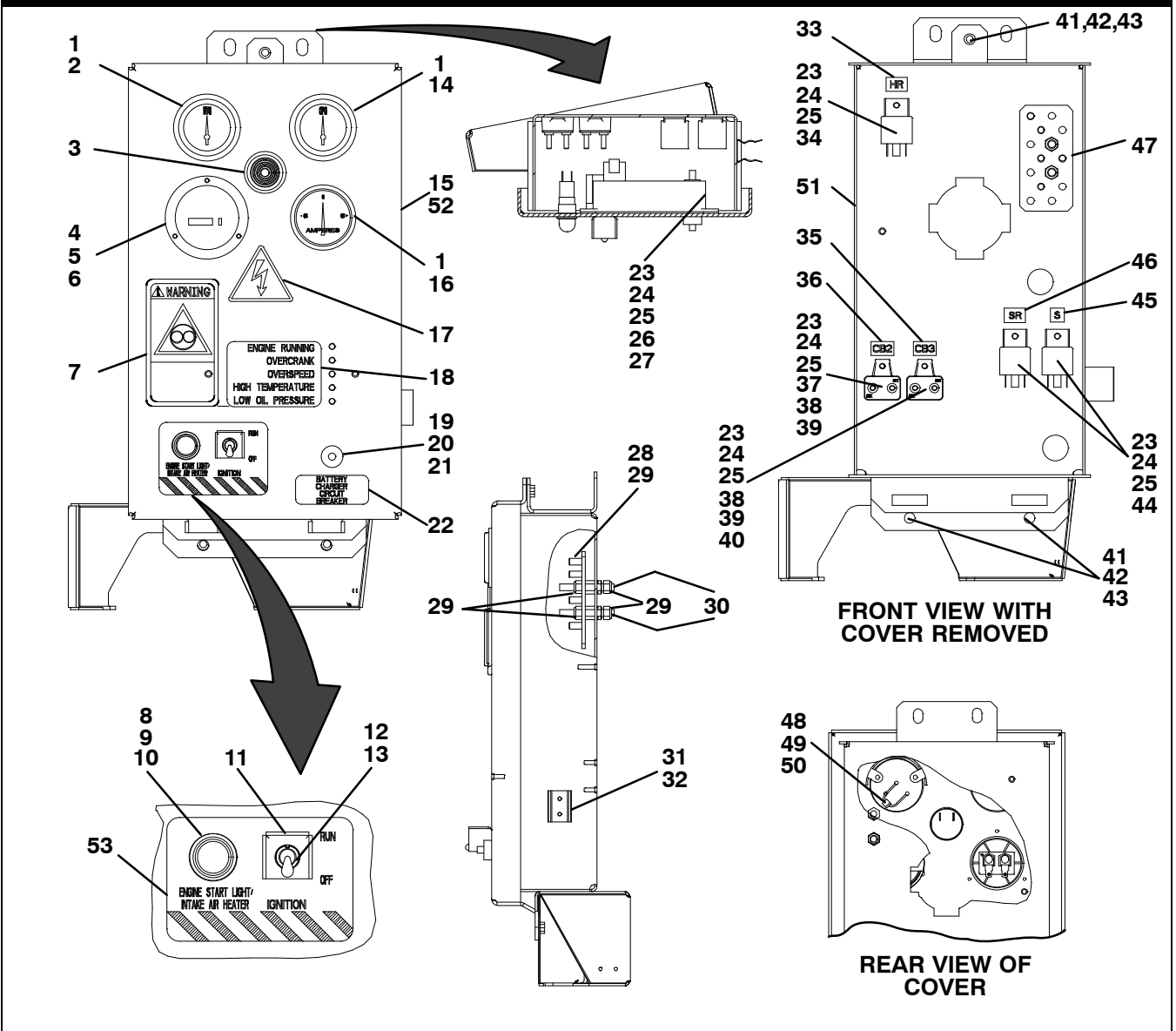

Item	Part Number	Description	Qty
	91-00398-XX	Control Box Assembly - Includes: - See 7.c,7.d	
1	KK71EW223	O-Ring	3
2	12-00097-03	Gauge, Water Temperature, 100-240 Degrees F, 12 VDC	1
3	42-00243-14	O-Ring	1
4	10-00448-00	Meter, Hour (Operating Range: 10-80 VDC)	1
5	66U1-6651-15	Screw, Machine, Pan Head Slotted, #4-40 x 0.75 Long, SST.	3
6	34-00667-05	Nut, Self Locking, #4-40, SST	3
7	62-02146-00	Label, WARNING, AUTO START	1
8	22-00049-00	Lamp, Incandescent, 12 VDC	1
9	22-00518-01	Base, Pilot Light	1
10	22-00519-01	Jewel Assembly, Pilot Light, Red	1
11	69GC15-3542	Bracket, Protector, Toggle Switch, Painted - See NOTE	A/R
12	66U1-9752	Seal, Bushing, 0.427/0.432	A/R
13	10-01129-18	Switch, Toggle, 2-Pole, On/Off	1
14	66U1-2823	Gauge, Oil Pressure, 0-100 PSI, 12 VDC	1

COMMON PARTS – CONTROL BOXES WITH AUTO RESTART, TIME DELAY, 2-SPEED (Continued)			
Item	Part Number	Description	Qty
15	42-00341-00	Gasket, Control Box	1
16	22-00538-01SV	Ammeter Gauge Kit, +60 /-60 Amp	1
17	62-03957-04	Label, HIGH VOLTAGE WARNING	1
18	62-10387-01	Label, LIGHTS	1
19	10-00365-00	Circuit Breaker, 3 Amp	1
20	KK71GW007	O-Ring	1
21	10-00365-10	Boot, Circuit Breaker	1
22	69GC15-3812	Label, BATTERY CHARGER CIRCUIT BREAKER	1
23	66U1-5331-4	Washer, Lock, #8, SST	7
24	34-00666-08	Nut, Hex, #8-32, SST	7
25	66U1-5321-2	Washer, Plain, Type A, #8, SST	7
26	12-00477-03	Module, Auto-Restart	1
27	42-00481-00	Gasket, Module, Auto-Restart	1
28	34-00372-41	Washer, Lock, External Tooth, 1/4, SST	4
29	34-00667-11	Nut, Self Locking, 1/4-20, SST	9
30	66U1-9592-13	Standoff, Hex Head, 1/4-20 x 0.375 x 1/4-20 x 0.75 Long, SST	2
31	44-00094-09	Clip, Spring, U" Type	1
32	34-00928-03	Rivet, Blind, 0.125 Diameter, Grip Range: 0.188 – 0.250, SST	2
33	66CH1-1002-38	Label, HR	1
34	10-00328-00	Relay, 70 Amp	1
35	66CH1-1002-5	Label, CB3	1
36	66U1-3662-21	Label, CB2	1
37	10-00171-13	Circuit Breaker, 50 Amp, 12 VDC	1
38	AT39QA132	Nut, Hex, #10-32, Brass	A/R
39	66U1-5331-3	Washer, Lock, #10, SST	4
40	10-00171-12	Circuit Breaker, 30 Amp, 12 VDC	1
41	66U1-5321-3	Washer, Plain, Type A, 1/4, SST	3
42	AU11JR171	Washer, Lock, 1/4, SST	3
43	66U1-5361-25	Screw, Hex Head, 1/4-20 x 0.75 Inch Long, SST	3
44	10-00286-02	Relay, SPDT, 30 Amp, With Diode	2
45	66CH1-1002-132	Label, S	1
46	62-10530-02	Label, SR	1
47	69NT41-982-2	Strap Assembly, Ground, Copper	1
48	22-01030-54	Diode Assembly, 6 Amp	1
49	22-02200-06	Washer, Plain, #6	2
50	34-00667-07	Nut, Self Locking, #6-32, SST	2
NS	66U1-3882	Wire Tie, Self-Locking, 7.00 Inches, Black	7
7.c	CONTROL BOX WITH AUTO RESTART (INCLUDES COMMON PARTS AND ITEMS BELOW)		
-	91-00398-00	Control Box Assembly, Auto-Restart, Painted – See NOTE	1
51	86-04231-06	Control Box	1
52	86-04165-05	Cover, Control Box, Auto-Restart, Painted	1
53	62-02973-04	Label, ENGINE START LIGHT, INTAKE AIR HEAT, IGNITION	1
7.d	CONTROL BOX WITH AUTO RESTART AND TIME DELAY (INCLUDES COMMON PARTS AND ITEMS BELOW)		
-	91-00398-01	Control Box Weld Assembly, Auto-Restart/Time Delay, Painted – See NOTE	1
51	86-04231-05	Control Box	1
52	86-04165-05	Cover, Control Box, Auto-Restart, Painted	1
53	62-02973-04	Label, ENGINE START LIGHT, INTAKE AIR HEAT, IGNITION	1

7.e CONTROL BOX WITH AUTO RESTART AND 2-SPEED (INCLUDES COMMON PARTS AND ITEMS BELOW)

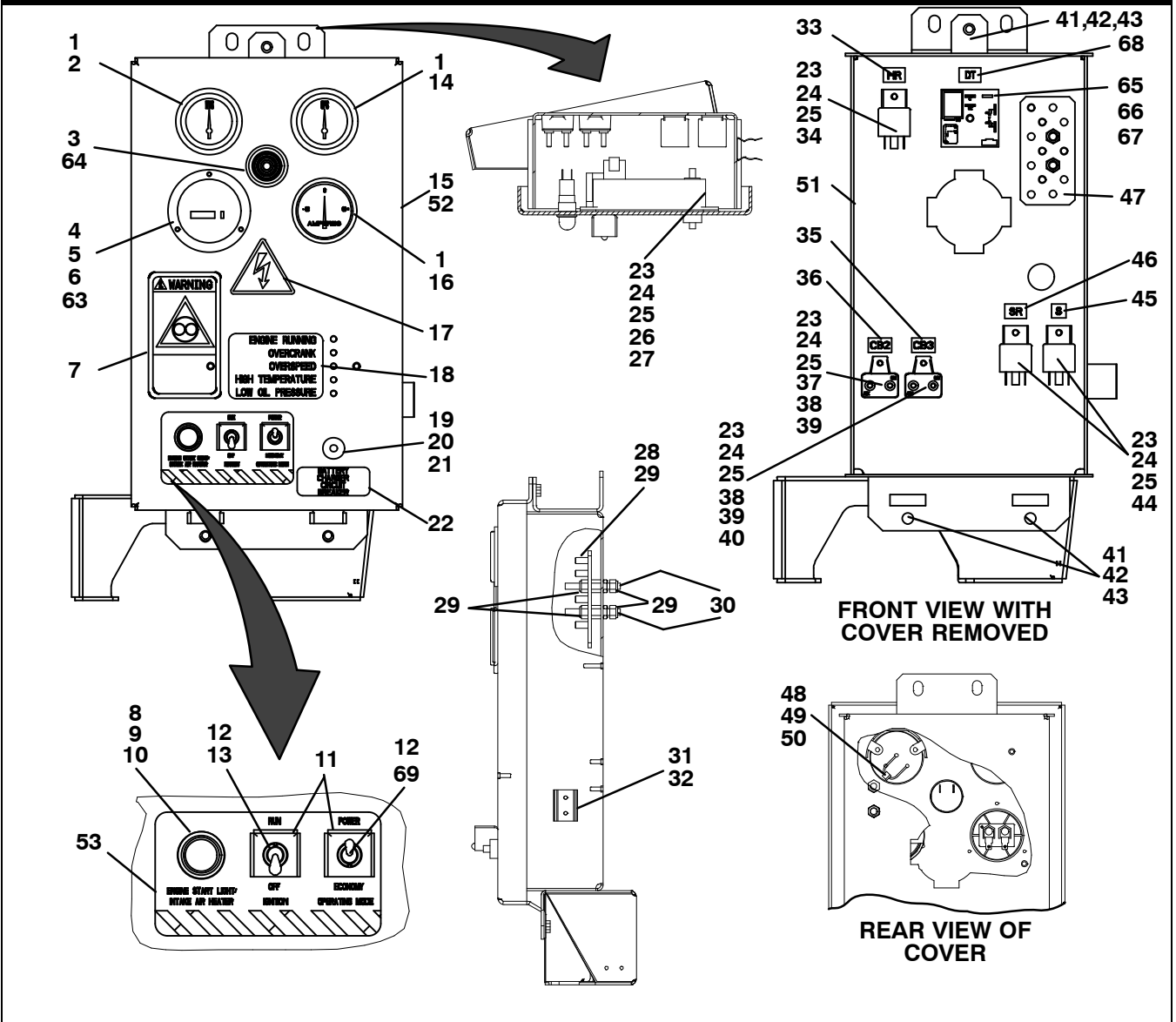

Item	Part Number	Description	Qty
-	91-00398-03	Control Box Assembly, Auto-Restart, 2-Speed, Painted - See NOTE	1
51	86-04231-09	Control Box	1
52	86-04165-09	Cover, Control Box, Auto-Restart, 2-Speed Painted	1
53	62-02973-05	Label, ENGINE START, IGNITION, 2-SPEED	1
63	69GS4-1582-1	Gasket	1
64	10-00375-01	Buzzer, Warning	1
65	66U1-5321-8	Washer, Plain, #10 Type A	1
66	34-00795-09	Nut, Self Lock, 10-32	1
67	10-00475-00	Timer, Time Delay, 2 Hour	1
68	66CH1-1002-89	Label	1
69	10-01129-18	Switch, Toggle, 1 Pole, On/Off	1

NOTE: See page ii for painted parts color system.

7.f CONTROL BOX, 2-SPEED, NON-SELECTABLE

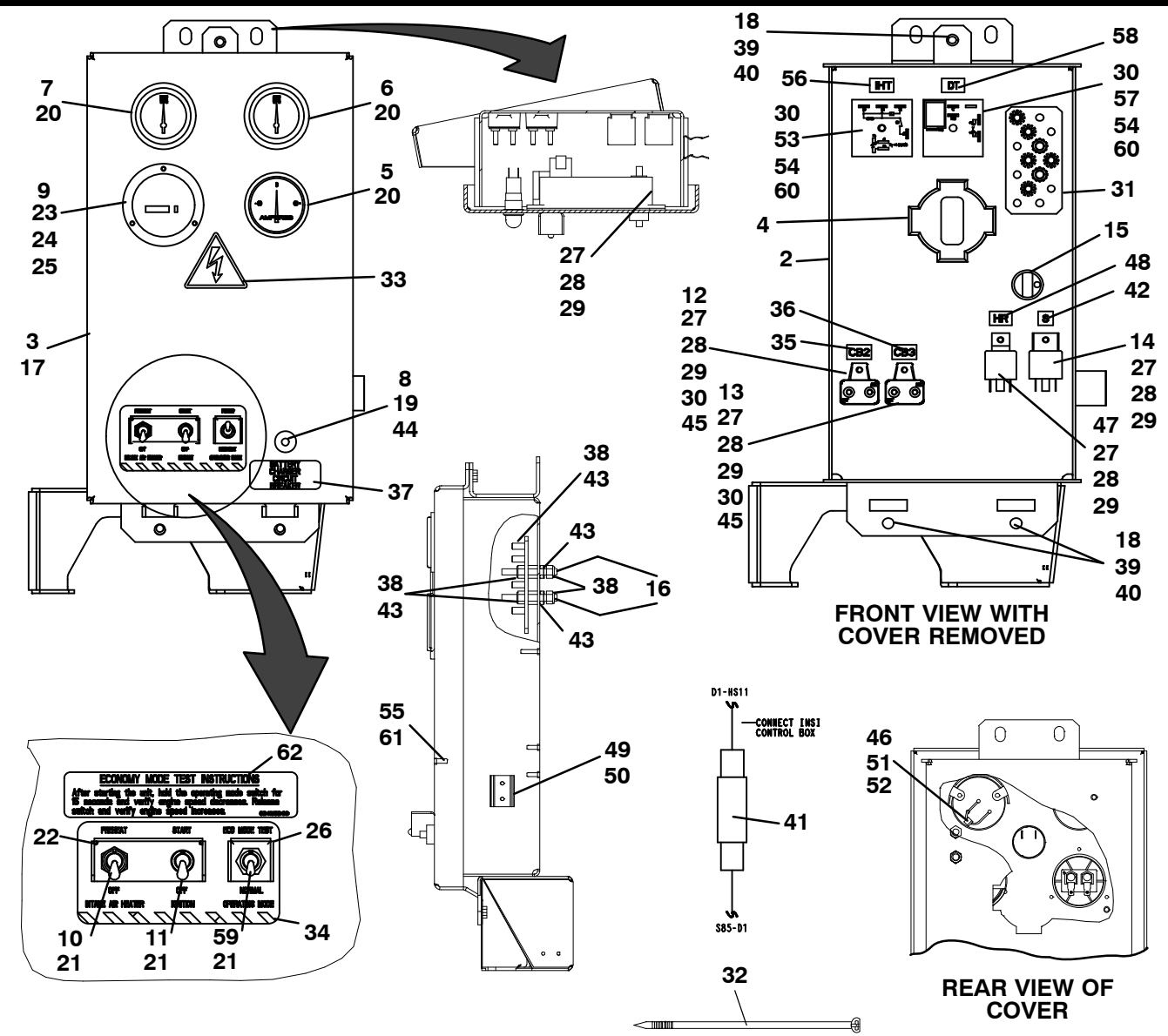

Item	Part Number	Description	Qty
1	91-00407-07	Control Box Assembly Includes -	1
2	86-04231-10	Box Assembly	1
3	86-04165-10	Cover	1
4	22-04139-06	Wire Harness - See Section 15.a	1
5	22-00538-01	Ammeter +60 /-60 Amps	1
6	66U1-2823	Gauge Oil Pressure	1
7	12-00097-03	Gauge Dual Water Temperature	1
8	10-00365-00	Circuit Breaker 3 Amp	1
9	10-00448-00	Meter, Hour	1
10	10-01129-19	Switch, Toggle 4-Pole	1
11	10-01129-14	Switch, Toggle On/On/On Momentary	1
12	10-00171-12	Circuit Breaker 30 Amp	1
13	10-00171-13	Circuit Breaker 50 Amp	1
14	10-00286-18	Relay	1
15	22-01790-02	Harness Battery Charger	1

7.f CONTROL BOX, 2-SPEED, NON-SELECTABLE			
Item	Part Number	Description	Qty
16	66U1-9592-13	Standoff 1/4-20 X 0.375 Long	2
17	42-00341-00	Gasket Control Box	1
18	66U1-5361-25	Screw,Cap Hex Head 1/4-20 X 0.75	3
19	KK71GW007	O-Ring	1
20	KK71EW223	O-Ring	1
21	66U1-9752	Seal	3
22	68-12973-00	Bracket	1
23	69GS4-1582-1	Gasket	1
24	66U1-6651-15	Screw,Mach Pan Head #4-40 X 3/4 Long	3
25	34-00667-05	Nut,Self Lock	3
26	69GC15-3542	Bracket	1
27	66U1-5331-4	Washer,Lock #8 Spring	4
28	34-00666-08	Nut,Hex #8-32	4
29	66U1-5321-2	Washer,Plain #8 Type A	4
30	66U1-5331-3	Washer,Lock #10 Spring	4
31	69NT41-982-2	Strap Assy Ground	1
32	58-00079-02	Strap	10
33	62-03957-04	Decal, Warning High Voltage	1
34	62-02669-03	Label, 2 Speed Switch	1
35	66U1-3662-21	Label, Cb2	1
36	66CH1-1002-5	Label, Cb3	1
37	69GC15-3812	Label, Battery Charger C.B.	1
38	34-00667-11	Nut,Self Lock	9
39	66U1-5321-3	Washer, Plain 1/4 N Type A	3
40	AU11JR171	Washer, Lock 1/4 Spring	3
41	66U1-8772	Diode 6 Amp	1
42	66CH1-1002-132	Label, S	1
43	34-00372-41	Washer,Lock 1/4	11
44	10-00365-10	Boot Circuit Breaker	1
45	AT39QA132	Nut,Hex #10-32	4
46	22-01030-54	Diode Assy 6 Amp	1
47	10-00328-00	Relay 70 Amp	1
48	66CH1-1002-38	Label, Hr	1
49	44-00094-09	Spring Clip	1
50	34-00928-03	Rivet, Blind .	2
51	22-02200-06	Washer,Plain #6	2
52	34-00667-07	Nut,Self Lock 11841	2
53	10-00469-00	Time Delay 12 Vdc	1
54	66U1-5321-8	Washer,Plain #10 Type A	2
55	34-00795-09	Nut,Self Lock 11963	2
56	62-10530-25	Label, Iht	1
57	10-00475-00	Timer, Time Delay, 2Hr	1
58	66CH1-1002-89	Label, Dt	1
59	10-01129-01	Switch,Toggle	1
60	34-00665-09	Nut,Hex	1
61	34-00372-39	Washer, Lock	1
62	62-11583-00	Label, ECONOMY MODE TEST INSTRUCTIONS	1

7.g CONTROL BOX WITH AUTO RESTART, TIME DELAY AND 2-SPEED (INCLUDES COMMON PARTS AND ITEMS BELOW)

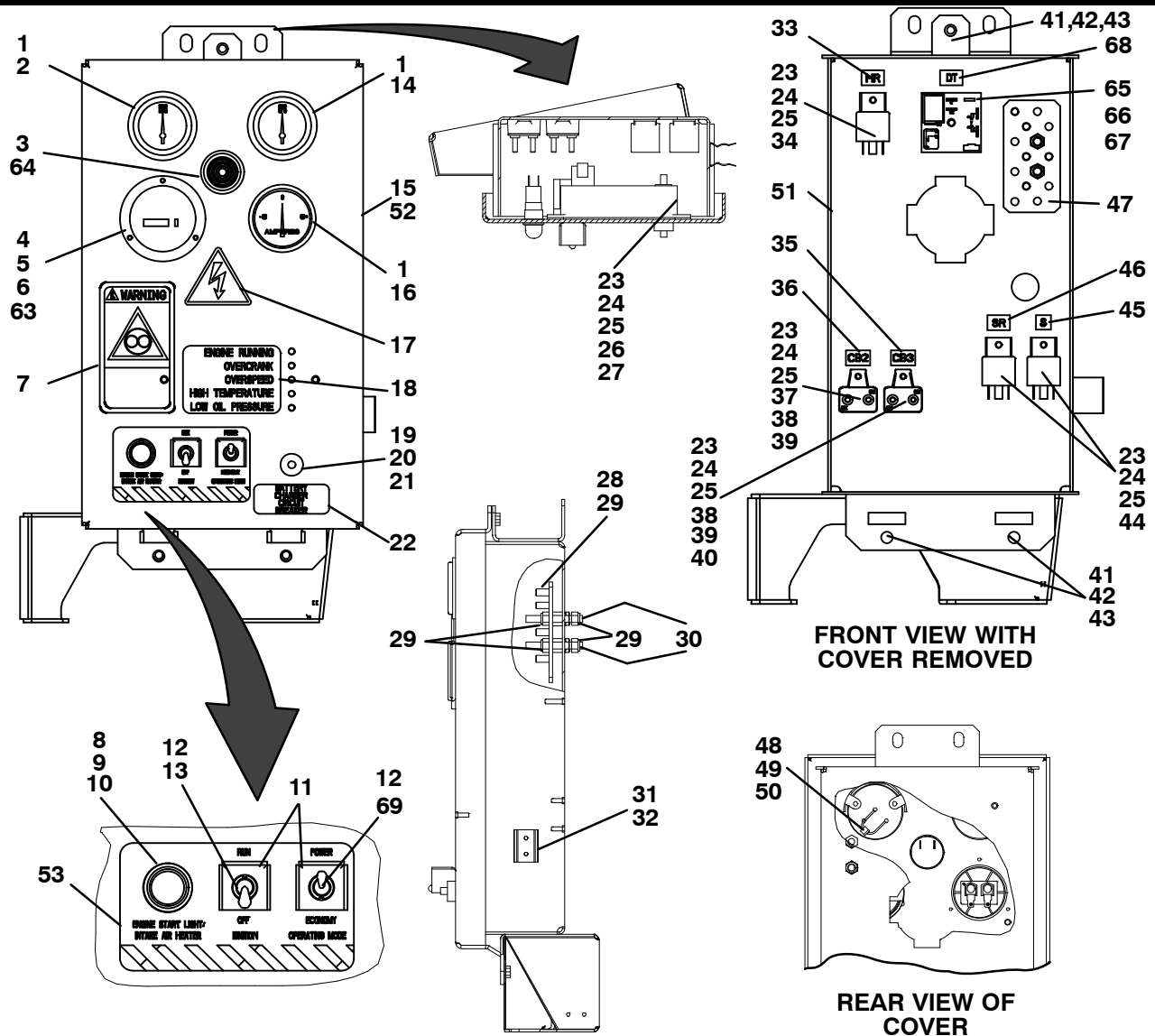

Item	Part Number	Description	Qty
-	91-00398-04	Control Box Assembly, Auto-Restart, Time Delay, 2-Speed, Painted - See NOTE	1
51	86-04231-08	Control Box	1
52	86-04165-09	Cover, Control Box, Auto-Restart, 2-Speed Painted	1
53	62-02973-05	Label, ENGINE START, IGNITION, 2-SPEED	1
63	69GS4-1582-1	Gasket	1
64	10-00375-01	Buzzer, Warning	1
65	66U1-5321-8	Washer, Plain, #10 Type A	1
66	34-00795-09	Nut, Self Lock, 10-32	1
67	10-00475-00	Timer, Time Delay, 2 Hour	1
68	66CH1-1002-89	Label	1
69	10-01129-18	Switch, Toggle, 1 Pole, On/Off	1

NOTE: See page ii for painted parts color system.

8 SOLID STATE BATTERY CHARGER

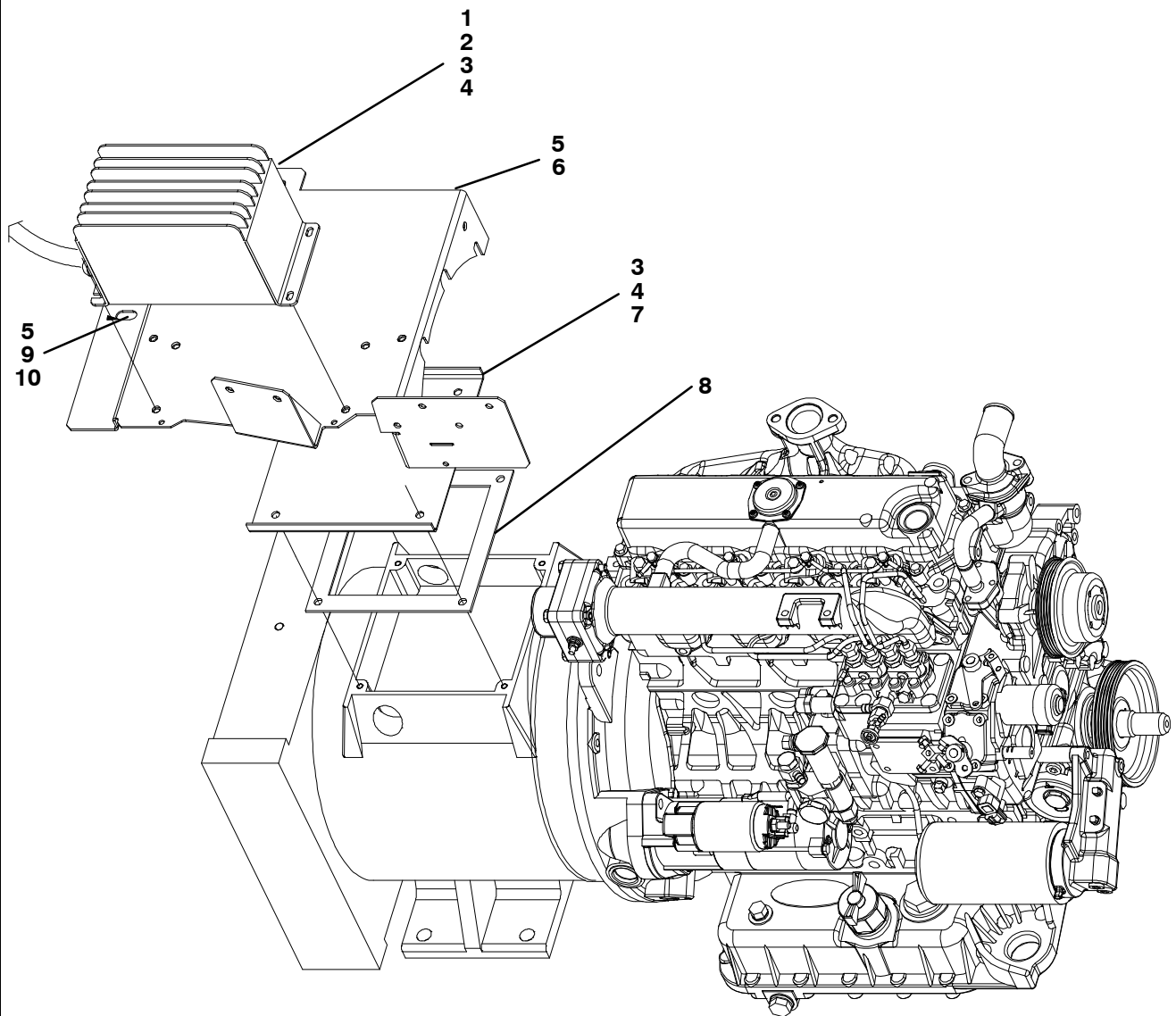

Item	Part Number	Description	Qty
1	30-00460-04	Battery Charger Assembly, 50 Amp – Includes:	1
2	34-06014-12	Screw, Cap Socket Head, 1/4-20 x 0.75 Inch Long, SST	4
3	AU11JR171	Washer, Split Lock, 1/4, SST	8
4	66U1-5321-3	Washer, Plain, Type A, 1/4, SST	8
5	34-00829-13	Washer, Plain, 3/8 SAE, SST	3
6	86-04752-00	Channel Assembly	1
7	68-12132-00	Channel, Battery Support, Painted	1
8	42-00348-00	Gasket	1
9	34-00807-08	Screw, Cap Hex Head, 3/8-16 x 1.00 Inch Long, SST	4
10	AU11JR241	Washer, Split Lock, 3/8, SST	1

9 VOLTAGE

9.a,9.b VOLTAGE

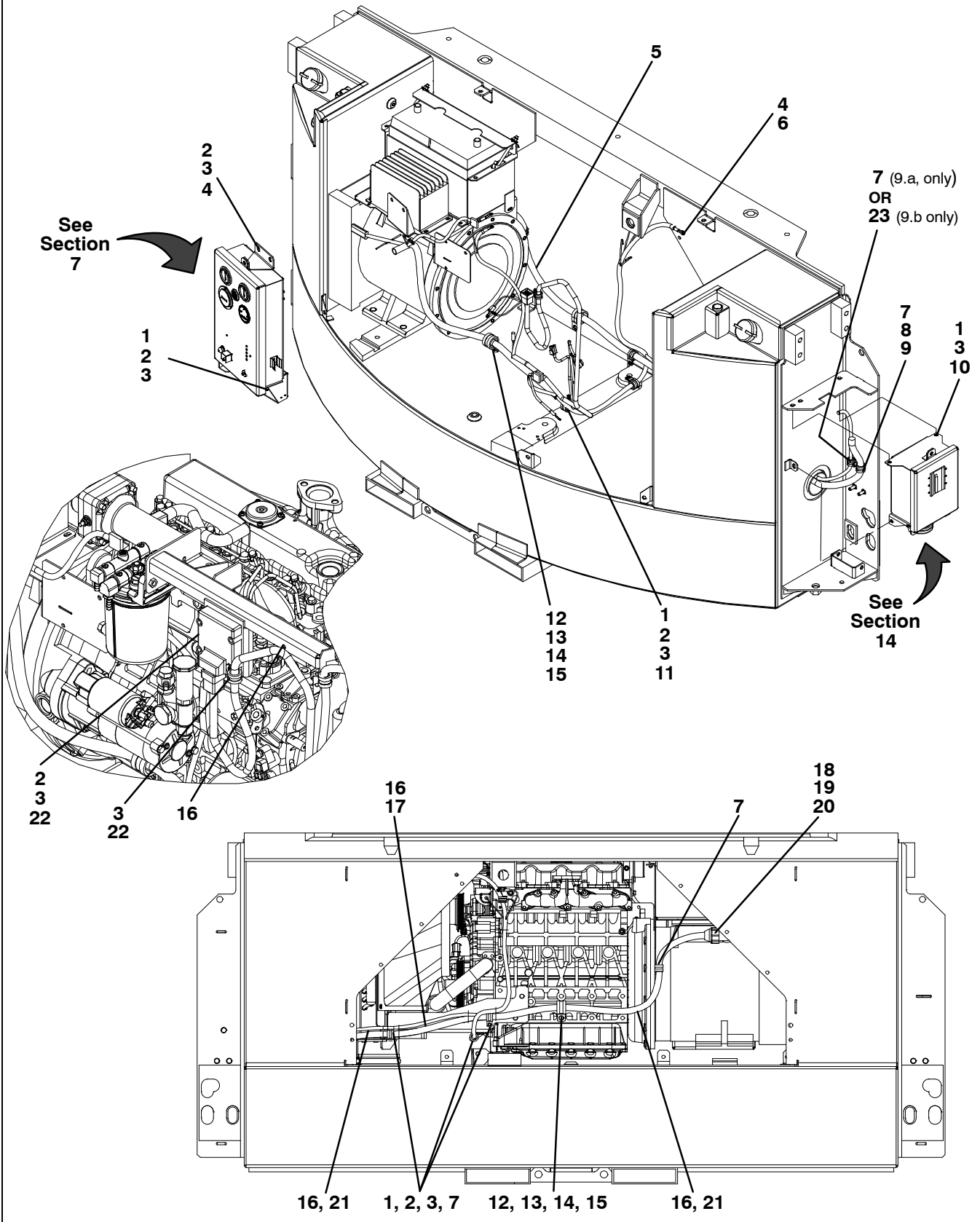

9.a,9.b VOLTAGE (Continued)			
Item	Part Number	Description	Qty
COMMON PARTS FOR SECTIONS 9.a,9.b (Continued)			
1	66U1-5361-25	Screw, Hex Head, 1/4-20 x 0.75 Inch Long, SST	9
2	66U1-5321-7	Washer, Plain, Type A, 1/4, SST	12
3	AU11JR171	Washer, Lock, 1/4, SST	15
4	34-00655-04	Screw, Cap, Hex Head, 1/4-20 x 0.50 Inch Long, SST	3
5	22-01764-01	Cable Assembly, Receptacle Box	1
6	34-00372-41	Washer, Lock, External Tooth, 1/4, SST	1
7	44-00102-54	Clamp, Hose, Cushioned, 0.75 OD, SST	5
8	34-00662-12	Washer, Plain, 5/16, SST	1
9	34-00667-12	Nut, Self Locking, 5/16-18, SST	1
10	69NT35-2692-1	Washer, Fender, 1/4, SST	3
11	44-00102-56	Clamp, Hose, Cushioned, 0.88 OD, SST	1
12	44-00102-59	Clamp, Hose, Cushioned, 1.25 OD, SST	2
13	34-01155-25	Screw, Hex Head, M12 x 25 MM Long, SST	2
14	34-01146-12	Washer, Split Lock, M12, SST	2
15	34-01151-12	Washer, Flat, M12, SST	2
16	66U1-3882	Wire Tie, Self-Locking, 7.00 Inches, Black	15
17	52-00850-18	Tubing, Split, Corrugated, 1.00 Inch OD x 11 Inches Long	1
18	66U1-8472-5	Connector, Watertight, 90 Degree, 1.00 Inch Hub	1
19	66U1-1251-3	O-Ring, Sealing, Zinc	1
20	34-06136-02	Nut, Lock, Nylon, 1.00 Inch NPT	1
21	58-00850-00	Tubing, Split, Corrugated, 1.00 Inch ID (Bulk)	1
22	66U1-5361-47	Bolt, Machine, Hex Head 1/4-20 x 1.25	4
9.a	VOLTAGE, 460 V (USED ON STANDARD UNIT OR UNIT WITH AUTO RESTART) (INCLUDES COMMON PARTS AND ITEMS BELOW)		
23	44-00102-52	Clamp, Hose, Cushioned, 0.56 OD, SST	1
9.b	VOLTAGE, 460 V (USED ON UNIT WITH POWER TIME DELAY AND AUTO RESTART) (INCLUDES COMMON PARTS AND ITEMS BELOW)		
7	44-00102-54	Clamp, Hose, Cushioned, 0.75 OD, SST	1

10 BATTERIES
10.a,10.b BATTERIES

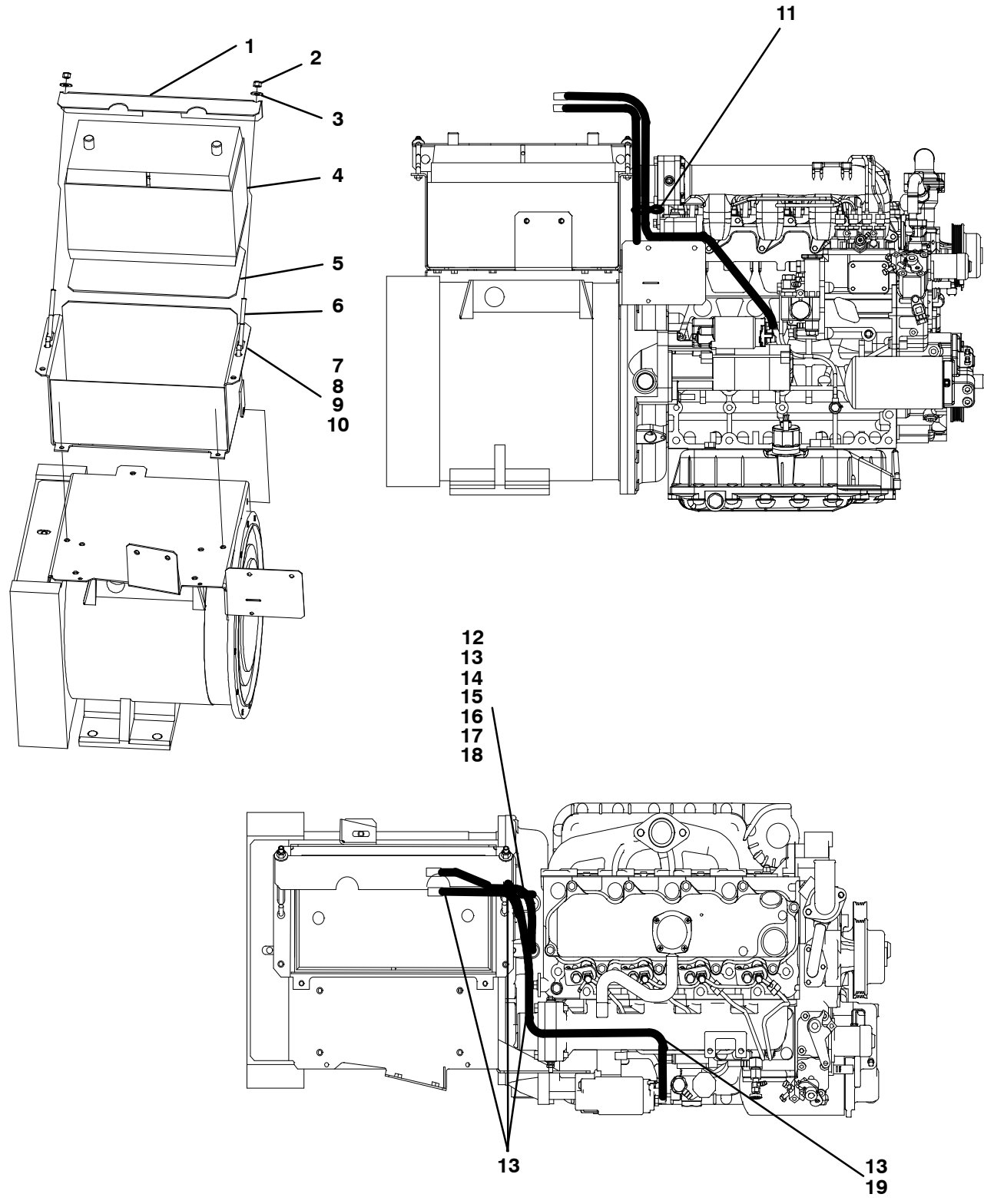

10.a,10.b BATTERIES (Continued)			
Item	Part Number	Description	Qty
BATTERIES – COMMON PARTS FOR OPTIONS 10.a, 10.b			
1	68-13946-00	Angle, Battery Hold Down, Painted	1
2	34-00667-12	Nut, Self Locking, 5/16-18, SST	2
3	34-00662-12	Washer, Plain, 5/16, SST	2
4	30-00358-04	Battery, 12VDC, 3/8-16 SST Screw Type Studs, Reserve Capacity in Minutes at 80 Degrees F (27 Degrees C) = 170 Minutes Cold Crank Amps at 0 Degrees F (-18 Degrees C) = 950 Amps	1
5	58-04503-00	Gasket, Battery Mat	1
6	34-06247-02	Bolt, "J" Hook, Battery Hold Down, 5/16-18 x 4.25 Inches Long, SST	2
7	86-04677-00	Battery Box Assembly, Painted	1
8	66U1-5361-25	Screw, Hex Head, 1/4-20 x 0.75 Inch Long, SST	4
9	AU11JR171	Washer, Split Lock, 1/4, SST	4
10	66U1-5321-3	Washer, Plain, Type A, 1/4, SST	4
11	58-00969-00	Wire Tie, 2.80 Diameter Double Loop	1
12	34-01151-08	Washer, Flat, M8, SST	1
13	66U1-3882	Wire Tie, Self-Locking, 7.00 Inches, Black	8
14	58-00848-00	Tubing, Split, Corrugated, 1/2 Inch ID x 90.00	A/R
15	34-00372-44	Washer, Lock, External Tooth, 7/16, SST	1
16	34-01153-15	Screw, Cap Hex Head, M8 x 15MM Long, SST	1
17	34-01151-08	Washer, Flat, M8, SST	1
10.a BATTERY – THREADED TYPE (INCLUDES COMMON PARTS AND ITEMS BELOW)			
18	22-01576-06	Battery Cable, Negative, Black, 24 Inches Long With Terminal Boot (#2 AWG)	1
19	22-01633-45	Battery Cable, Positive, Red, 28 Inches Long With Terminal Cap (#2 AWG)	1
10.b BATTERY – POST TYPE (INCLUDES COMMON PARTS AND ITEMS BELOW)			
18	22-01633-47	Battery Cable, Negative, Black, 26 Inches Long With Terminal Boot (#2 AWG)	1
19	22-01633-46	Battery Cable, Positive, Red, 28 Inches Long With Terminal Boot (#2 AWG)	1

11 EXHAUST SYSTEM

11.a,11.b EXHAUST SYSTEM – STEEL, WITH AND WITHOUT GUARD

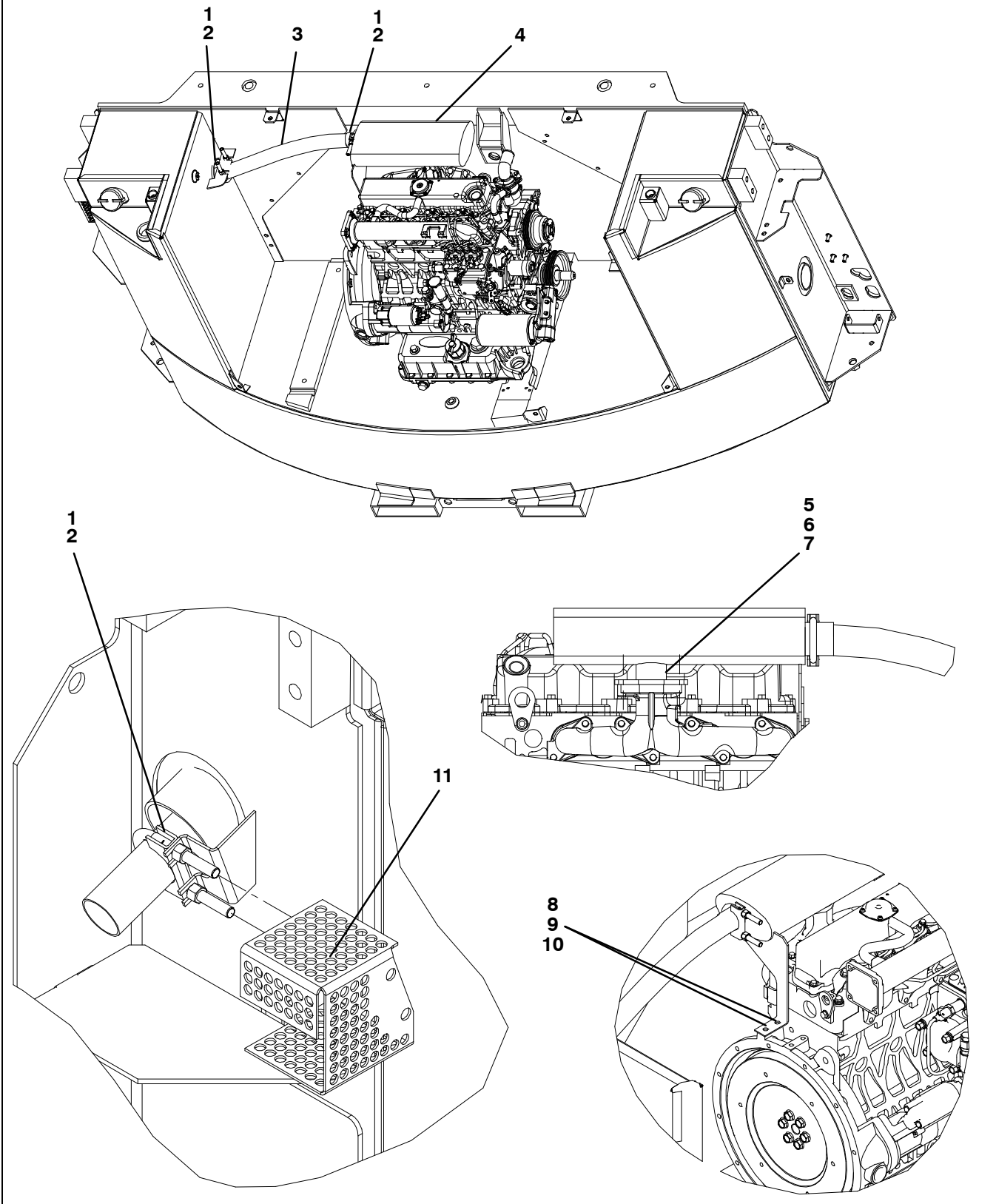

11.a, 11.b EXHAUST SYSTEM – STEEL, WITH AND WITHOUT GUARD (Continued)			
Item	Part Number	Description	Qty
11.a ALUMINIZED STEEL MUFFLER			
1	30-00427-00	Clamp, U-Bolt, 3/8-16, Zinc	3
2	AU11JR241	Washer, Split Lock, 3/8, SST	6
3	30-00435-01	Pipe, Flexible, 1.50 ID x 40.25 Inches Long, SST	1
4	30-00424-02	Muffler, Kubota Engine, Aluminized Steel	1
5	34-00964-00	Stud, M10 x 3/8-24 x 1.50 Inches Long	2
6	34-00932-13	Nut, Jam, 3/8-24, Brass	4
7	66U1-5321-5	Washer, Plain, Type A, 3/8, SST	2
8	34-01146-08	Washer, Split Lock, M8, SST	2
9	34-01151-08	Washer, Flat, M8, SST	2
10	34-01153-15	Screw, Cap Hex Head, M8 x 15MM Long, SST	2
11.b ALUMINIZED STEEL MUFFLER, CE, WITH GUARD (INCLUDES ALL OF OPTION 11.a AND ITEM BELOW):			
11	68-12838-00	Guard, Exhaust	1

12 LABELS

1

Carrier Transicold Division
Carrier Corporation
Syracuse, New York

TRANSICOLD

DIESEL FUEL TANK
MEETS ALL F.H.W.A. REQUIREMENTS FOR
NON-SIDE-MOUNTED FUEL TANKS

PART NO. CAPACITY U.S. GAL DATE OF MFG.
XXXXX-XXXX-XX LIQ. [XXX.X] DRAW [XXX.X] [XX-XXXX]

WARNING
DO NOT FILL TO MORE THAN 96% OF LIQUID CAPACITY

2

WARNING

**UNIT MAY
START
AUTOMATICALLY**

62-02146-00 REV_A

3

**WARNING
CUIDADO**

**SHUT UNIT OFF
BEFORE
REFUELING**

**APAGAR
LA UNIDAD
ANTES DE AÑADIR
COMBUSTIBLE**

62-02937-00 REV -

4

WARNING

6

**CAUTION
CUIDADO**

CTD P/N 62-02972-00 REV. -

7

WARNING

**BOLT MUST BE IN PLACE AND
TORQUED PROPERLY
125 ± 25 FT-LBS**

Proper bolt length is provided for I.S.O. recommended design.
ENSURE BOLT DRAWS UNIT TIGHT TO CONTAINER.
Non-standard containers may require special bolt lengths.

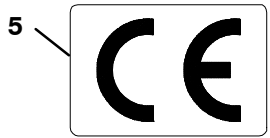

10

OPERATING MODE switch positions
POWER = High speed, full power, for maximum cooling
ECONOMY = Reduced speed, fuel saver, for in-range cargo

<p>START</p> <ul style="list-style-type: none"> Set Start/Stop switch [1] to the Refrigeration Start position [1]. Set Generator [2] to position [1]. Set OPERATING MODE switch to desired position. For standard operation place the STOP/OFF switch in the [OFF] position. Unit will start after a 30 second time delay. If unit does not start, it will attempt to start again in 25 seconds. IMPORTANT: An extra alarm sounds and a light illuminates to warn of unit start-up. Once unit starts, the labels air heater, light and motor alarm remain on for an additional 3 minutes. Set Generator [2] to position [1]. Set Refrigeration Start in accordance with instructions. 	<p>ARRANQUE</p> <ul style="list-style-type: none"> Coloque el interruptor de Start/Stop [1] en la Unidad de Refrigeración en la posición [1]. Coloque el generador [2] en la posición [1]. Coloque el interruptor OPERATING MODE en la posición deseada. Para una operación normal coloque el interruptor STOP/OFF en la posición [OFF]. La unidad arrancará después de 30 segundos. Si la unidad no arranca, la unidad tratará de arrancar nuevamente después de 25 segundos. IMPORTANTE: Una alarma suena y las indicadoras le avisan cuando la unidad está por arrancar. Una vez encendida la unidad, el calentador de la toma de aire, la luz y la alarma suena permanecerá encendida por 3 minutos adicionales. Coloque el Generador [2] en la posición [1]. Arranque la Unidad de Refrigeración de acuerdo a las instrucciones.
<p>STOP</p> <ul style="list-style-type: none"> Place STOP/OFF switch in the [OFF] position. 	<p>PARO</p> <ul style="list-style-type: none"> Coloque el interruptor STOP/OFF en la posición [OFF].

CALIFORNIA
Proposition 65 Warning
Diesel engine exhaust and some of its constituents are known to the State of California to cause cancer, birth defects, and other reproductive harm.
62-11448-01 REV A

8

Carrier

TRANSICOLD

9

POWERLINE

Item	Part Number	Description	Qty
1	62-10571-00	Label, Warning, Diesel Fuel Tank	A/R
2	62-02146-00	Decal, Warning, Auto Start	A/R
3	62-02937-00	Label, Refueling	A/R
4	62-02895-00	Label, Danger, Fan Warning	A/R
5	62-02785-00	Label, CE (European Conformity)	A/R
6	62-02972-00	Label, Hot Surface - English/Spanish	A/R
7	62-02897-00	Label, Bolt Torque	A/R
8	62-03882-09	Decal, Carrier Transicold	A/R
9	62-10395-00	Label, Powerline	A/R
10	62-11448-01	Label, Start/Stop/ 2 Speed	A/R

12 LABELS (Continued)

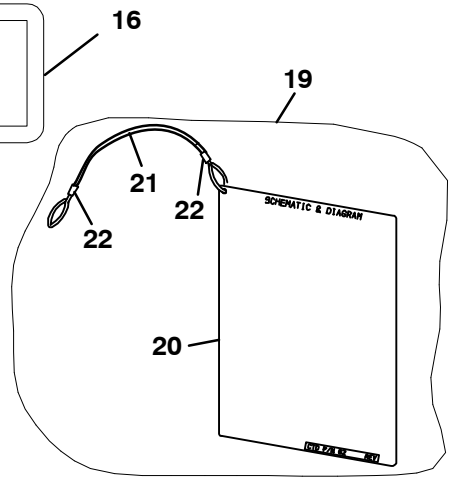
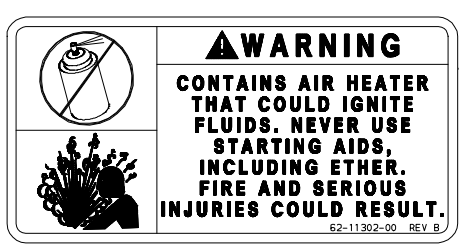
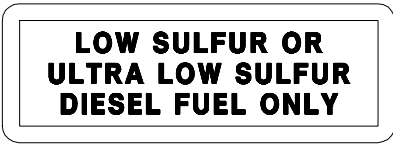
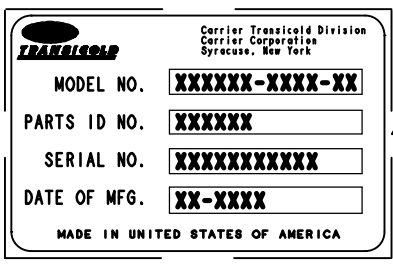
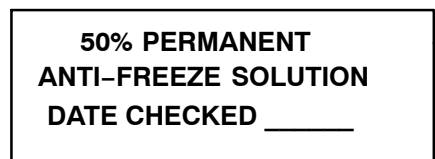
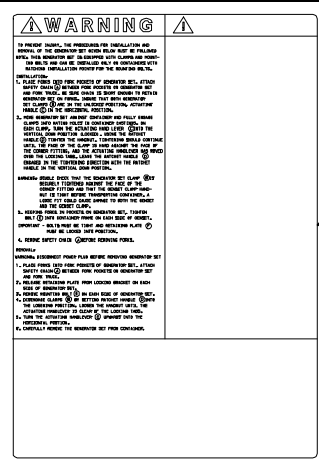
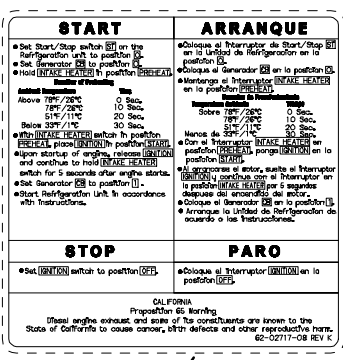
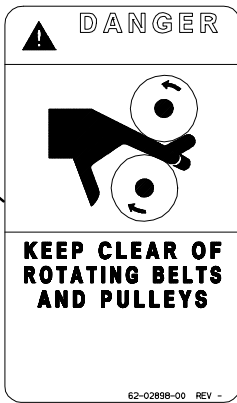

Item	Part Number	Description	Qty
11	62-02898-00	Label, Rotation - English/Spanish	A/R
12	62-02717-08	Label, Start-Stop - English/Spanish	A/R
	62-02717-07	Label, Start-Stop - English/Spanish (Auto Restart)	A/R
13	62-02899-02	Label, Installation - Pin Unit	A/R
	62-02899-03	Label, Installation - Clamp Unit	A/R
14	62-02896-00	Label, Safety Chains	A/R
15	69GS4-1702	Label, Anti-Freeze	A/R
16	62-02181-01	Decal, Diesel Fuel Only	A/R
17	62-10572-00	Label, Genset	A/R
18	62-11302-00	Warning Decal, Ether	A/R
NS	62-10391-01	Label, Protective	A/R

12.a RETROFIT LABELS

19	79-01909-07	Plate Assembly - Includes:	1
20	62-11445-00	Plate 69 Rg Schematic/Art,2Speed	1
21	58-01097-00	Cord,Nylon	1
22	22-02205-00	Connector	2

13 SKINS OPTION

13.a,13.b SKINS WITH TOP ACCESS DOORS AND BUMPERS, RIVNUTS, CE

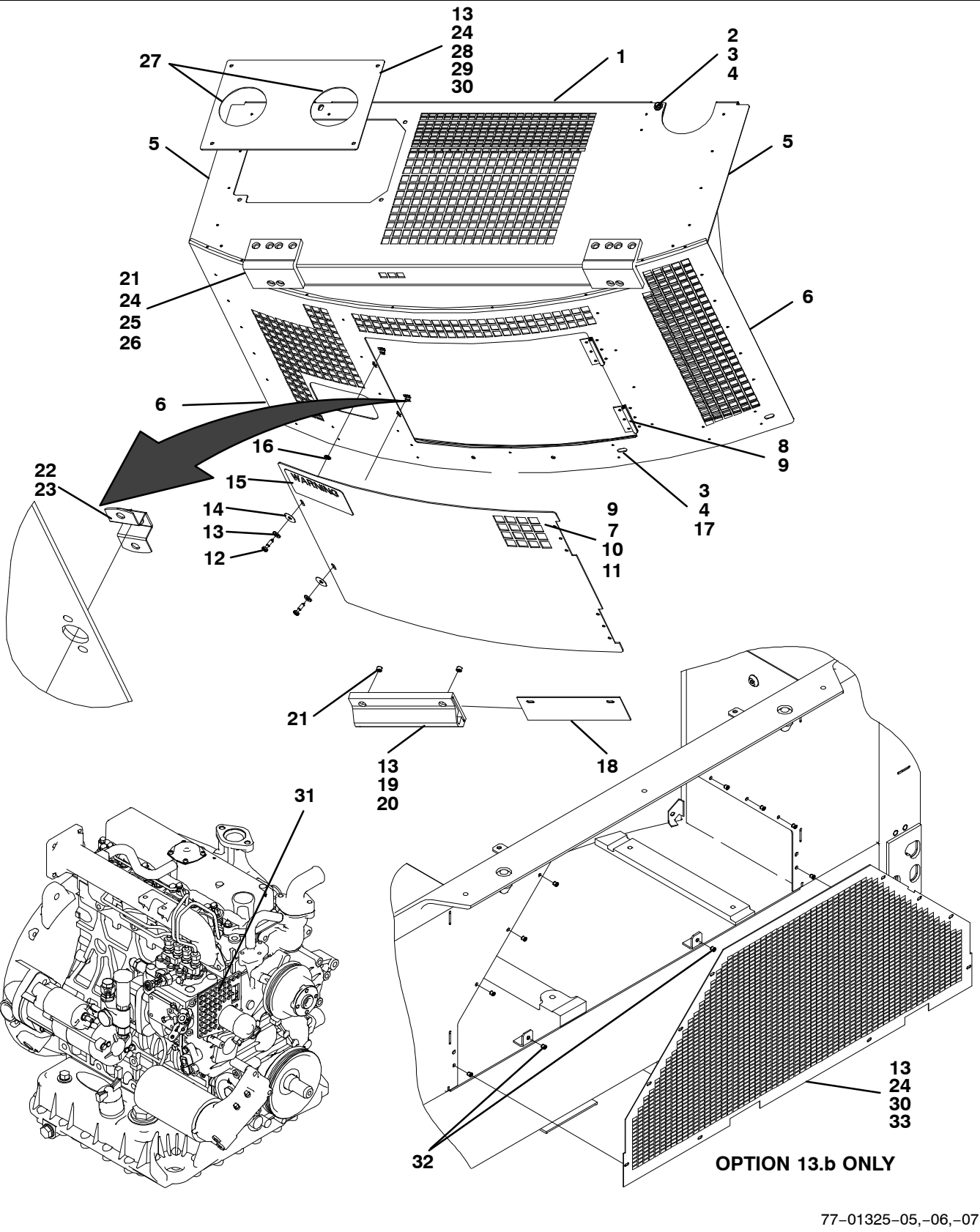

13.a,13.b SKINS WITH TOP ACCESS DOORS AND BUMPERS, CE (Continued)			
Item	Part Number	Description	Qty
13.a SKINS OPTION WITH TOP ACCESS DOOR AND BUMPER, CE			
1	86-04680-03	Cover Assembly	1
2	66U1-5361-39	Screw, Cap Hex Head, 5/16-18 x 1.00 Inch Long, SST	4
3	34-00663-12	Washer, Split Lock, 5/16, SST	5
4	34-00662-12	Washer, Plain, 5/16, SST	5
5	42-00363-00	Gasket, Cover, Neoprene, Adhesive Backed	2
6	42-00363-01	Gasket, Cover, Neoprene, Adhesive Backed	4
7	79-01674-08	Door Assembly, Access - Includes:	1
8	44-00352-00	Hinge, Access Door, SST	2
9	34-00928-13	Rivet, Blind, 0.187 Diameter, Grip Range: 0.126 - 0.250, SST	12
10	68-12540-00	Door, Access	1
11	66U1-2552-124	Gasket, Access Door, Neoprene, Adhesive Backed	2
12	66U1-6811-12	Screw, Retaining, #2 Phillips, SST	2
13	66U1-5321-3	Washer, Plain, Type A, 1/4, SST	6
14	34-06053-03	Washer, Mylar, 0.250 ID x 1.00 OD	2
15	62-11302-00	Decal, Warning - Ether	1
16	34-01226-00	Washer, Retaining, Nylon, Black	2
17	66U1-5361-38	Screw, Cap Hex Head, 5/16-18 x 1.50 Inches Long, SST	1
18	68-13483-00	Plate, Bumper	1
19	58-04402-00	Bumper, Black	1
20	34-00655-08	Screw, Cap Hex Head, 1/4-20 x 1.00 Inch Long, SST	2
21	34-01219-03	Spacer, SST	10
22	34-01142-01	Receptacle, #12, Saddle Type, SST	2
23	34-00928-01	Rivet, Blind, 0.125 Diameter, Grip Range: 0.063 - 0.125, SST	4
24	66U1-5361-25	Screw, Cap Hex Head, 1/4-20 x 0.75 Inch Long, SST	12
25	58-04433-00	Bumper, Neoprene, Black	2
26	34-00588-11	Washer, Plain, 1/4 SAE, Zinc	8
27	66CH1-1172-59	Trim, Flexible, 16.50 Inches Long, White	2
28	68-12186-00	Cover, Battery - See NOTE	1
29	42-00486-01	Gasket, Access Panel, Neoprene, Adhesive Backed	1
30	AU11JR171	Washer, Split Lock, 1/4, SST	14
31	68-15575-00	Bracket, Guard	1
32	34-06051-07	Rivnut, 1/4-20	10
13.b SKINS OPTION WITH TOP ACCESS DOOR, BUMPER AND REAR COVER, CE (INCLUDES ALL OF OPTION 13.a AND ITEMS BELOW)			
13	66U1-5321-3	Washer, Plain, Type A, 1/4, SST	10
24	66U1-5361-25	Screw, Cap Hex Head, 1/4-20 x 0.75 Inch Long, SST	10
33	68-12536-00	Cover, Rear - See NOTE	1

NOTE: See page ii for painted parts color system.

13.c SKINS OPTION WITH TOP ACCESS DOOR AND BUMPER

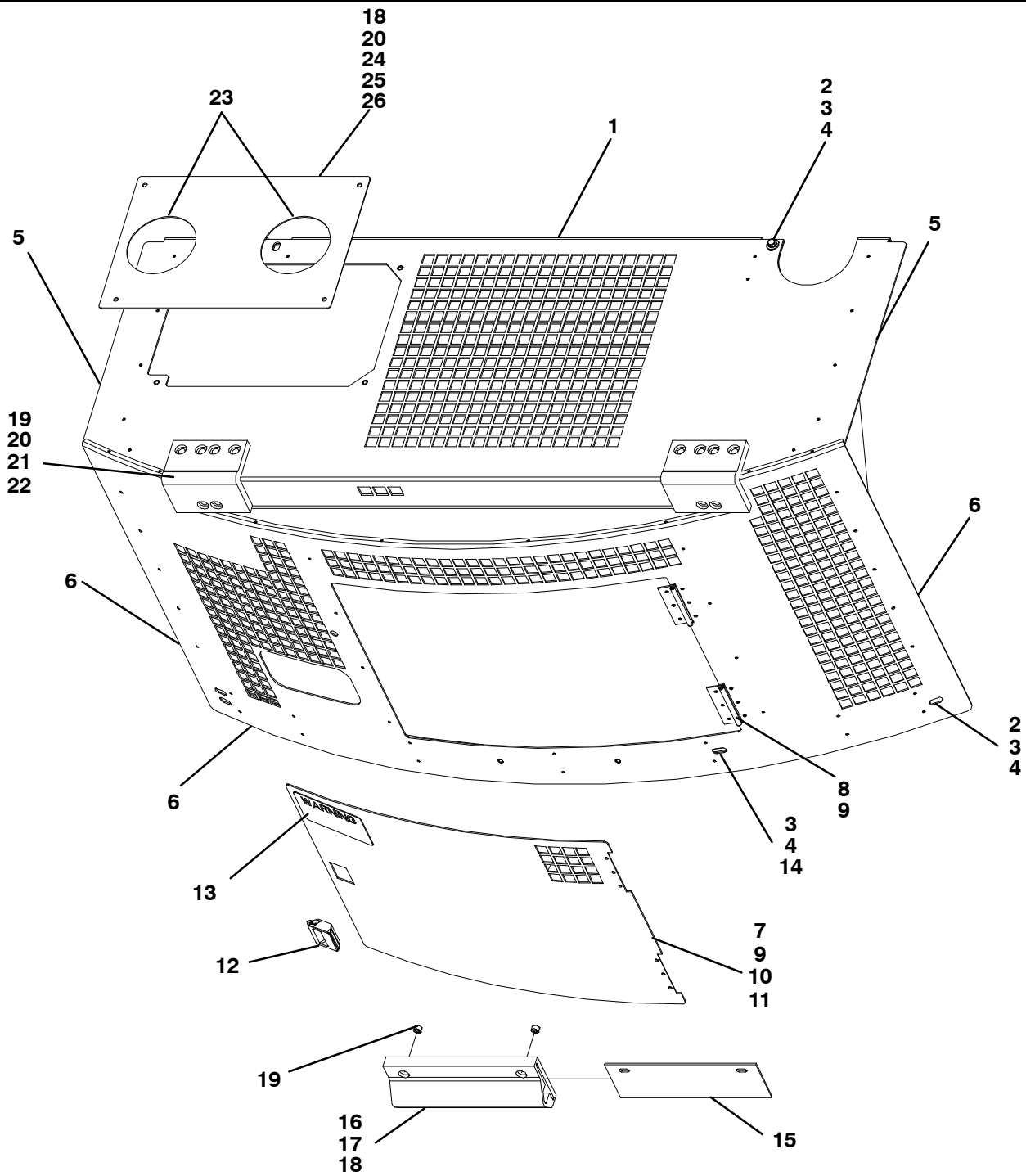

77-01325-00

13.c SKINS OPTION WITH TOP ACCESS DOOR AND BUMPER (Continued)			
Item	Part Number	Description	Qty
1	86-04680-00	Cover Assembly	1
2	66U1-5361-39	Screw, Cap Hex Head, 5/16-18 x 1.00 Inch Long, SST	4
3	34-00663-12	Washer, Split Lock, 5/16, SST	5
4	34-00662-12	Washer, Plain, 5/16, SST	5
5	42-00363-00	Gasket, Cover, Neoprene, Adhesive Backed	2
6	42-00363-01	Gasket, Cover, Neoprene, Adhesive Backed	4
7	79-01674-05	Door Assembly, Access - Includes:	1
8	44-00352-00	Hinge, Access Door, SST	2
9	34-00928-13	Rivet, Blind, 0.187 Diameter, Grip Range: 0.126 - 0.250, SST	12
10	68-12110-02	Door, Access	1
11	66U1-2552-124	Gasket, Access Door, Neoprene, Adhesive Backed	2
12	44-00401-00	Latch, Door Spring Loaded	1
13	62-11302-00	Decal, Warning - Ether	1
14	66U1-5361-38	Screw, Cap Hex Head, 5/16-18 x 1.50 Inches Long, SST	1
15	68-13483-00	Plate, 0.125 Thick Aluminum	1
16	58-04402-00	Bumper, Black	1
17	34-00655-08	Screw, Cap Hex Head, 1/4-20 x 1.00 Inch Long, SST	2
18	66U1-5321-3	Washer, Plain, Type A, 1/4, SST	6
19	34-01219-03	Spacer, SST	10
20	66U1-5361-25	Screw, Cap Hex Head, 1/4-20 x 0.75 Inch Long, SST	12
21	58-04433-00	Bumper, Neoprene, Black	2
22	34-00588-11	Washer, Plain, 1/4 SAE, Zinc	8
23	66CH1-1172-59	Trim, Flexible, 16.50 Inches Long, White	2
24	68-12186-00	Cover, Battery - See NOTE	1
25	42-00486-01	Gasket, Access Panel, Neoprene, Adhesive Backed	1
26	AU11JR171	Washer, Split Lock, 1/4, SST	4

NOTE: See page ii for painted parts color system.

13.d SKINS OPTION WITH TOP ACCESS DOOR, BUMPER AND DOCUMENT HOLDER

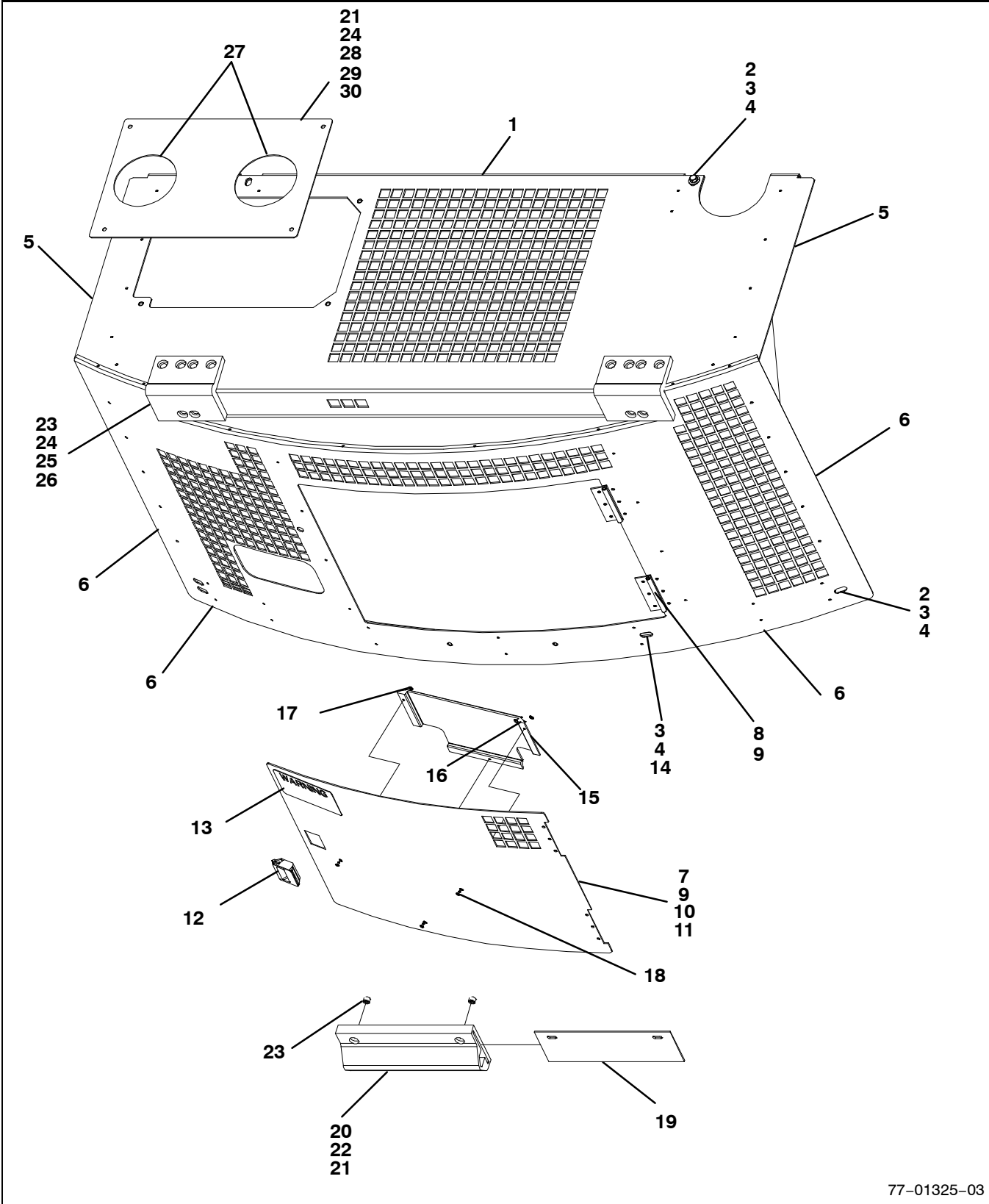

77-01325-03

13.d SKINS OPTION WITH TOP ACCESS DOOR, BUMPER AND DOCUMENT HOLDER (Continued)			
Item	Part Number	Description	Qty
1	86-04680-00	Cover Assembly	1
2	66U1-5361-39	Screw, Cap Hex Head, 5/16-18 x 1.00 Inch Long, SST	4
3	34-00663-12	Washer, Split Lock, 5/16, SST	5
4	34-00662-12	Washer, Plain, 5/16, SST	5
5	42-00363-00	Gasket, Cover, Neoprene, Adhesive Backed	2
6	42-00363-01	Gasket, Cover, Neoprene, Adhesive Backed	4
7	79-01674-05	Door Assembly, Access - Includes:	1
8	44-00352-00	Hinge, Access Door, SST	2
9	34-00928-13	Rivet, Blind, 0.187 Diameter, Grip Range: 0.126 - 0.250, SST	12
10	68-12110-03	Door, Access	1
11	66U1-2552-124	Gasket, Access Door, Neoprene, Adhesive Backed	2
12	44-00401-00	Latch, Door Spring Loaded	1
13	62-11302-00	Decal, Warning - Ether	1
14	66U1-5361-38	Screw, Cap Hex Head, 5/16-18 x 1.50 Inches Long, SST	1
15	58-04389-00	Pocket, 69NT Placard	1
16	66U1-3882	Wire Tie, Self locking	1
17	AU53VA061	Washer, Gasket, 0.125 Diameter Rivet	3
18	34-06107-00	Rivet, Blind, 0.125 Diameter, Grip Range: 0.188 - 0.250, SST	3
19	68-13483-00	Plate, 0.125 Thick Aluminum	1
20	58-04402-00	Bumper, Black	1
21	66U1-5321-3	Washer, Plain, Type A, 1/4, SST	6
22	34-00655-08	Screw, Cap Hex Head, 1/4-20 x 1.00 Inch Long, SST	2
23	34-01219-03	Spacer, SST	10
24	66U1-5361-25	Screw, Cap Hex Head, 1/4-20 x 0.75 Inch Long, SST	12
25	58-04433-00	Bumper, Neoprene, Black	2
26	34-00588-11	Washer, Plain, 1/4 SAE, Zinc	8
27	66CH1-1172-59	Trim, Flexible, 16.50 Inches Long, White	2
28	68-12186-00	Cover, Battery - See NOTE	1
29	42-00486-01	Gasket, Access Panel, Neoprene, Adhesive Backed	1
30	AU11JR171	Washer, Split Lock, 1/4, SST	4

NOTE: See page ii for painted parts color system.

13.e SKINS OPTION WITH TOP ACCESS DOOR

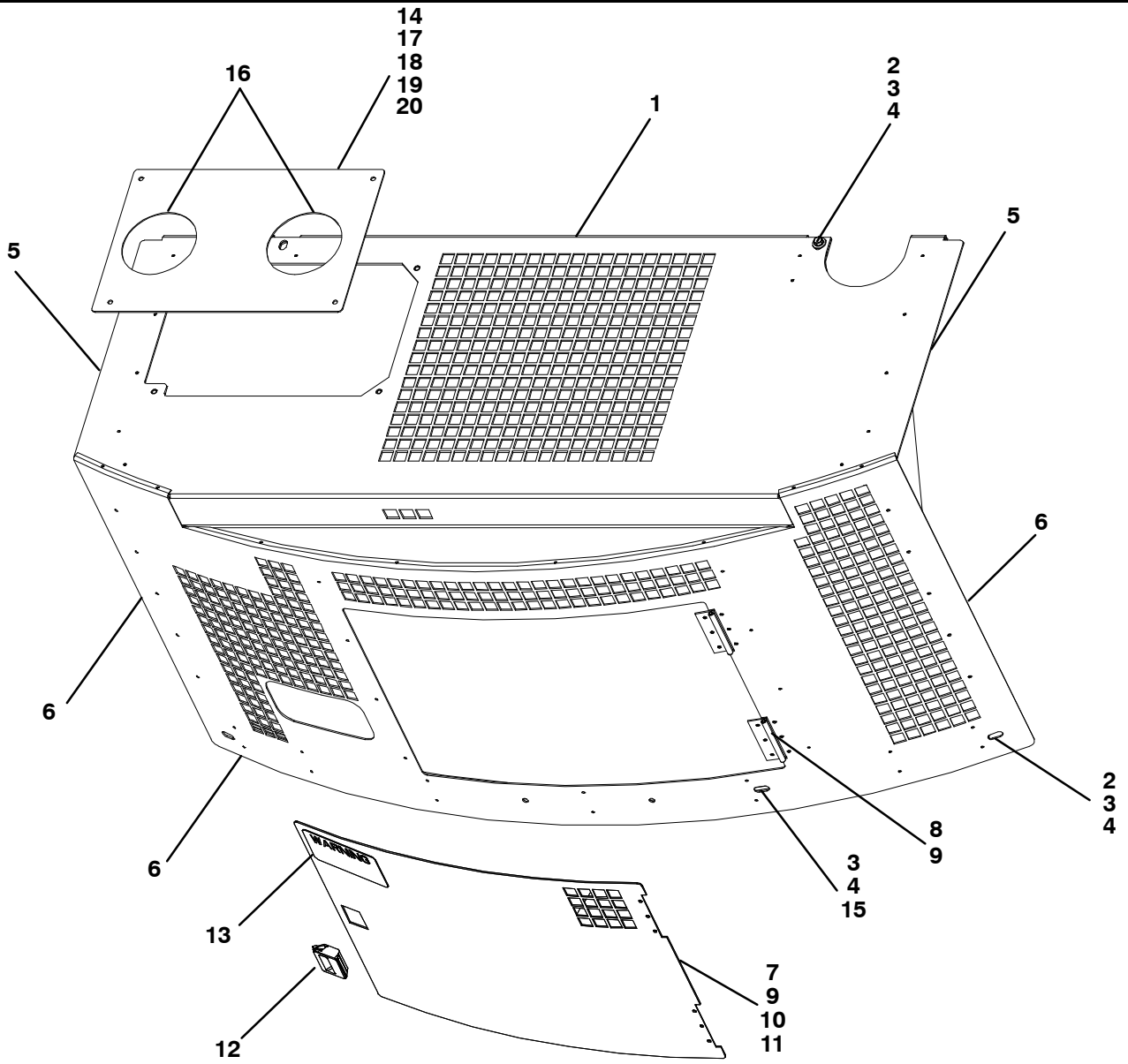

13.e SKINS OPTION WITH TOP ACCESS DOOR (Continued)			
Item	Part Number	Description	Qty
1	86-04680-02	Cover Assembly	1
2	66U1-5361-39	Screw, Cap Hex Head, 5/16-18 x 1.00 Inch Long, SST	4
3	34-00663-12	Washer, Split Lock, 5/16, SST	5
4	34-00662-12	Washer, Plain, 5/16, SST	5
5	42-00363-00	Gasket, Cover, Neoprene, Adhesive Backed	2
6	42-00363-01	Gasket, Cover, Neoprene, Adhesive Backed	4
7	79-01674-05	Door Assembly, Access - Includes:	1
8	44-00352-00	Hinge, Access Door, SST	2
9	34-00928-13	Rivet, Blind, 0.187 Diameter, Grip Range: 0.126 - 0.250, SST	12
10	68-12110-02	Door, Access	1
11	66U1-2552-124	Gasket, Access Door, Neoprene, Adhesive Backed	2
12	44-00401-00	Latch, Door Spring Loaded	1
13	62-11302-00	Decal, Warning - Ether	1
14	66U1-5321-3	Washer, Plain, Type A, 1/4, SST	4
15	66U1-5361-38	Screw, Cap Hex Head, 5/16-18 x 1.50 Inches Long, SST	1
16	66CH1-1172-59	Trim, Flexible, 16.50 Inches Long, White	2
17	66U1-5361-25	Screw, Cap Hex Head, 1/4-20 x 0.75 Inch Long, SST	4
18	68-12186-00	Cover, Battery - See NOTE	1
19	42-00486-01	Gasket, Access Panel, Neoprene, Adhesive Backed	1
20	AU11JR171	Washer, Split Lock, 1/4, SST	4

NOTE: See page ii for painted parts color system.

13.f SKINS OPTION

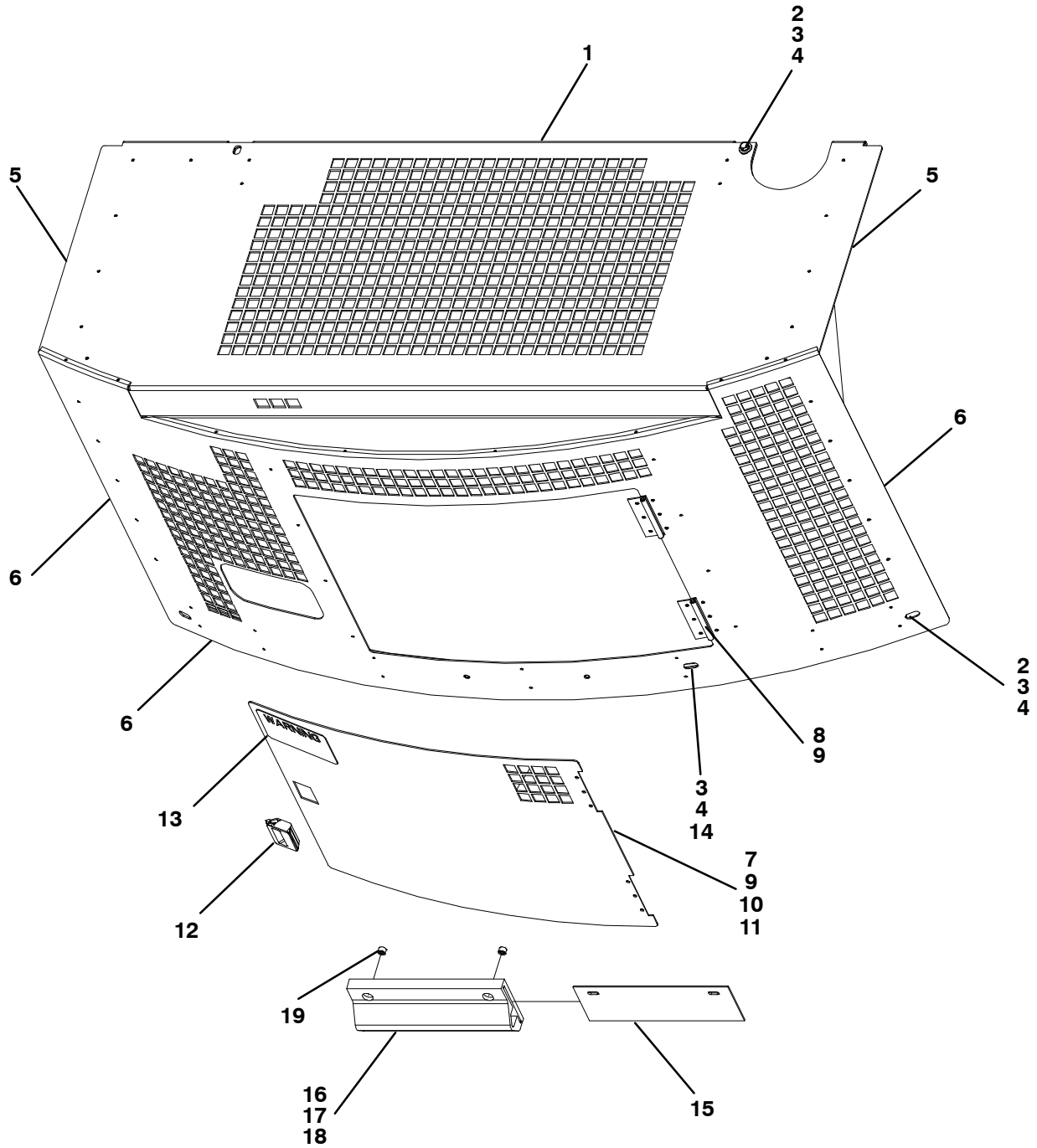

77-01325-01

13.f SKINS OPTION (Continued)			
Item	Part Number	Description	Qty
1	86-04680-01	Cover Assembly	1
2	66U1-5361-39	Screw, Cap Hex Head, 5/16-18 x 1.00 Inch Long, SST	4
3	34-00663-12	Washer, Split Lock, 5/16, SST	5
4	34-00662-12	Washer, Plain, 5/16, SST	5
5	42-00363-00	Gasket, Cover, Neoprene, Adhesive Backed	2
6	42-00363-01	Gasket, Cover, Neoprene, Adhesive Backed	4
7	79-01674-05	Door Assembly, Access - Includes:	1
8	44-00352-00	Hinge, Access Door, SST	2
9	34-00928-13	Rivet, Blind, 0.187 Diameter, Grip Range: 0.126 - 0.250, SST	12
10	68-12110-02	Door, Access	1
11	66U1-2552-124	Gasket, Access Door, Neoprene, Adhesive Backed	2
12	44-00401-00	Latch, Door Spring Loaded	1
13	62-11302-00	Decal, Warning - Ether	1
14	66U1-5361-38	Screw, Cap Hex Head, 5/16-18 x 1.50 Inches Long, SST	1
15	68-13483-00	Plate, 0.125 Thick Aluminum	1
16	58-04402-00	Bumper, Black	1
17	34-00655-08	Screw, Cap Hex Head, 1/4-20 x 1.00 Inch Long, SST	2
18	66U1-5321-3	Washer, Plain, Type A, 1/4, SST	2
19	34-01219-03	Spacer, SST	2

NOTE: See page ii for painted parts color system.

13.g SKINS OPTION WITH BUMPER (TIR)

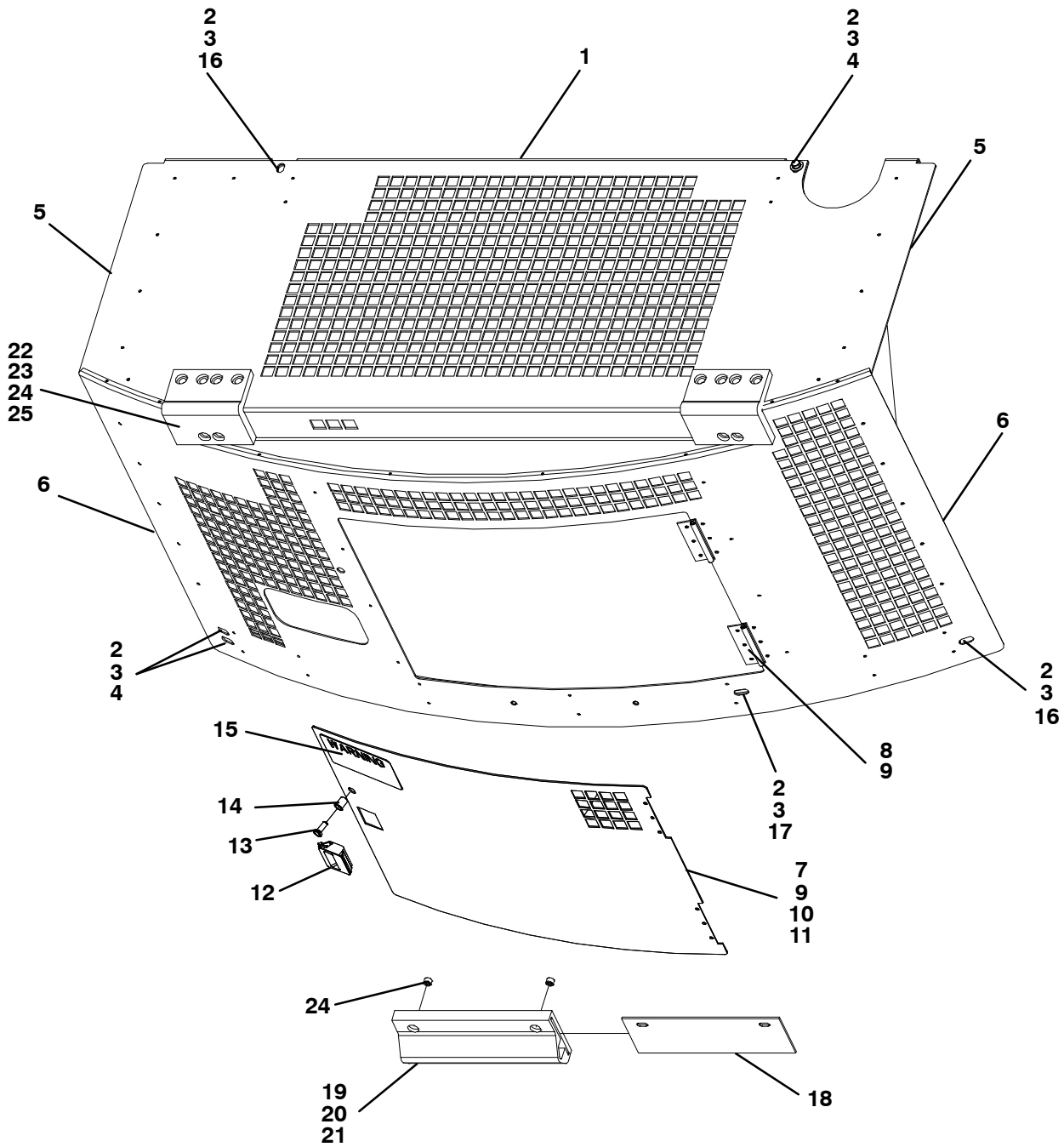

77-01325-04

13.g SKINS OPTION WITH BUMPER (TIR) (Continued)			
Item	Part Number	Description	Qty
1	86-04680-04	Cover Assembly	1
2	34-00663-12	Washer, Split Lock, 5/16, SST	5
3	34-00662-12	Washer, Plain, 5/16, SST	5
4	34-06154-01	Screw, Cap Hex Head, 1/4-20 x 1.00 Inch Long, TIR	2
5	42-00363-00	Gasket, Cover, Neoprene, Adhesive Backed	2
6	42-00363-01	Gasket, Cover, Neoprene, Adhesive Backed	4
7	79-01674-06	Door Assembly, Access – Includes:	1
8	44-00352-00	Hinge, Access Door, SST	2
9	34-00928-13	Rivet, Blind, 0.187 Diameter, Grip Range: 0.126 – 0.250, SST	12
10	68-12110-04	Door, Access	1
11	66U1-2552-124	Gasket, Access Door, Neoprene, Adhesive Backed	2
12	44-00401-00	Latch, Door Spring Loaded	1
13	34-06154-02	Screw, Cap Hex Head, 5/16-18 x 0.75 Inch Long, TIR	1
14	34-06051-40	Rivnut, 5/16-18	1
15	62-11302-00	Decal, Warning – Ether	1
16	66U1-5361-39	Screw, Cap Hex Head, 5/16-18 x 1.00 Inch Long, SST	2
17	66U1-5361-38	Screw, Cap Hex Head, 5/16-18 x 1.50 Inches Long, SST	1
18	68-13483-00	Plate, 0.125 Thick Aluminum	1
19	58-04402-00	Bumper, Black	1
20	34-00655-08	Screw, Cap Hex Head, 1/4-20 x 1.00 Inch Long, SST	2
21	66U1-5321-3	Washer, Plain, Type A, 1/4, SST	2
22	66U1-5361-25	Screw, Cap Hex Head, 1/4-20 x 0.75 Inch Long, SST	8
23	58-04433-00	Bumper, Neoprene, Black	2
24	34-01219-03	Spacer, SST	10
25	34-00588-11	Washer, Plain, 1/4 SAE, Zinc	8

NOTE: See page ii for painted parts color system.

13.h SKINS OPTION WITH ACCESS HOLES, BUMPER, RIVNUTS

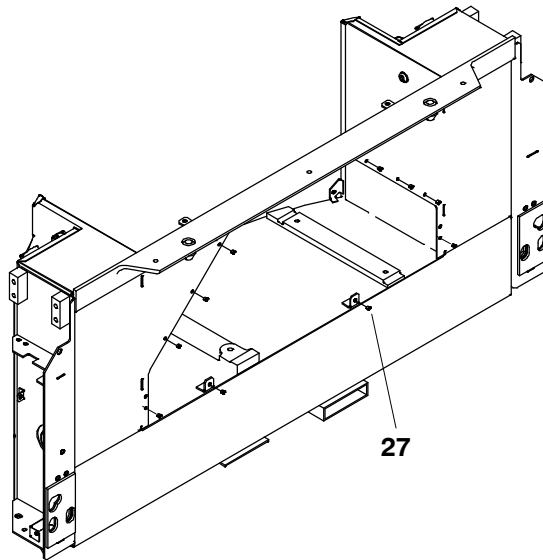
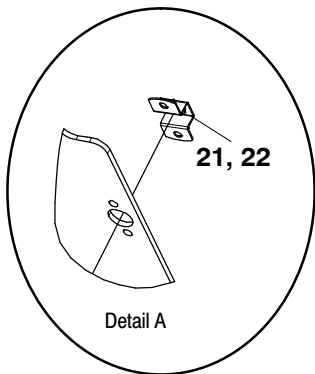
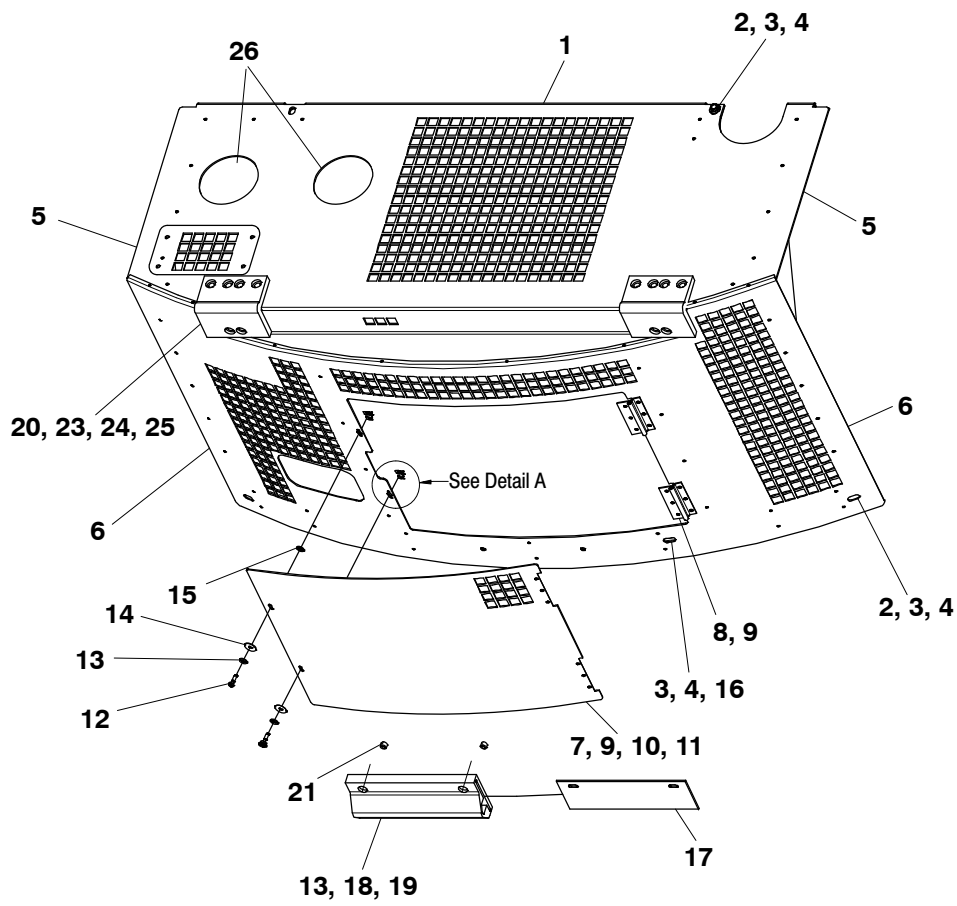

77-01430-02

13.h SKINS OPTION WITH ACCESS HOLES, BUMPER, RIVNUTS (Continued)

Item	Part Number	Description	Qty
1	86-04680-03	Cover Assembly	1
2	66U1-5361-39	Screw, Cap Hex Head, 5/16-18 x 1.00 Inch Long, SST	4
3	34-00663-12	Washer, Split Lock, 5/16, SST	5
4	34-00662-12	Washer, Plain, 5/16, SST	5
5	42-00363-00	Gasket, Cover, Neoprene, Adhesive Backed	2
6	42-00363-01	Gasket, Cover, Neoprene, Adhesive Backed	4
7	79-01674-08	Door Assembly, Access - Includes:	1
8	44-00352-00	Hinge, Access Door, SST	2
9	34-00928-13	Rivet, Blind, 0.187 Diameter, Grip Range: 0.126 - 0.250, SST	12
10	68-12540-00	Door, Access	1
11	66U1-2552-124	Gasket, Access Door, Neoprene, Adhesive Backed	2
12	66U1-6811-12	Screw, Retaining, #2 Phillips, SST	2
13	66U1-5321-3	Washer, Plain, Type A, 1/4, SST	6
14	34-06053-03	Washer, Mylar, 0.250 ID x 1.00 OD	2
15	34-01226-00	Washer, Retaining, Nylon, Black	2
16	66U1-5361-38	Screw, Cap Hex Head, 5/16-18 x 1.50 Inches Long, SST	1
17	68-13483-00	Plate, Bumper	1
18	58-04402-00	Bumper, Black	1
19	34-00655-08	Screw, Cap Hex Head, 1/4-20 x 1.00 Inch Long, SST	2
20	58-00836-23	Spacer, SST	10
21	34-01142-01	Receptacle, #12, Saddle Type, SST	2
22	34-00928-01	Rivet, Blind, 0.125 Diameter, Grip Range: 0.063 - 0.125, SST	4
23	66U1-5361-25	Screw, Cap Hex Head, 1/4-20 x 0.75 Inch Long, SST	12
24	58-04433-00	Bumper, Neoprene, Black	2
25	34-00588-11	Washer, Plain, 1/4 SAE, Zinc	8
26	66CH1-1172-59	Trim, Flexible, 16.50 Inches Long, White	2
27	34-06051-07	Rivnut, 1/4-20	10

14 RECEPTACLE BOX ASSEMBLY

14.a,14.b,14.c RECEPTACLES

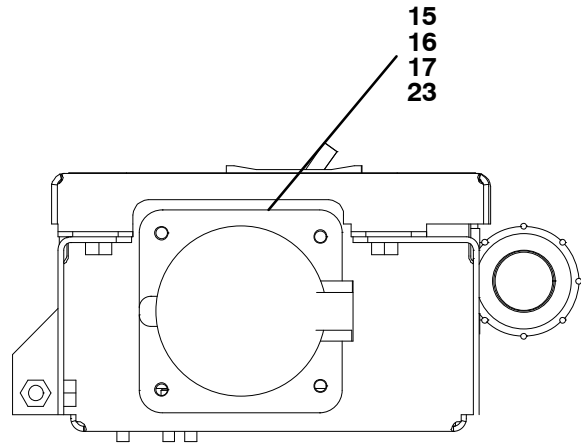
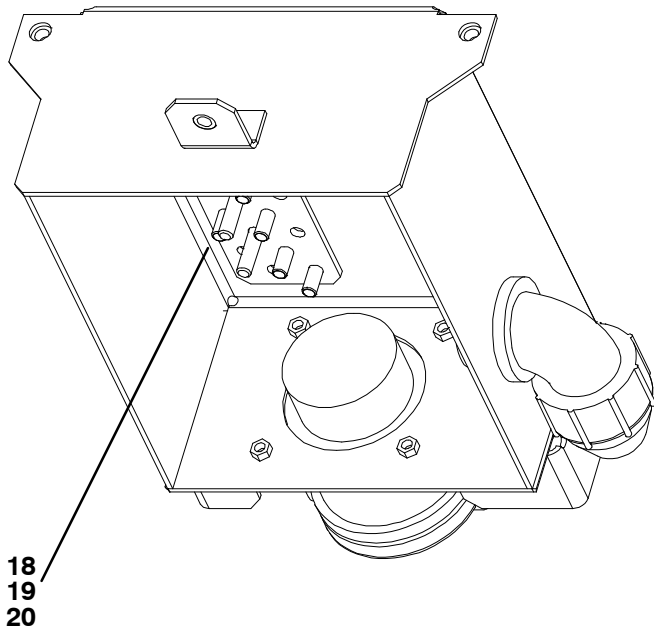
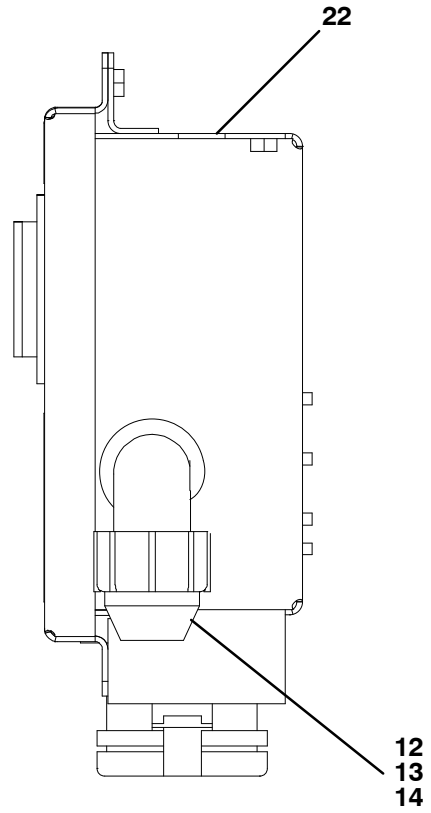
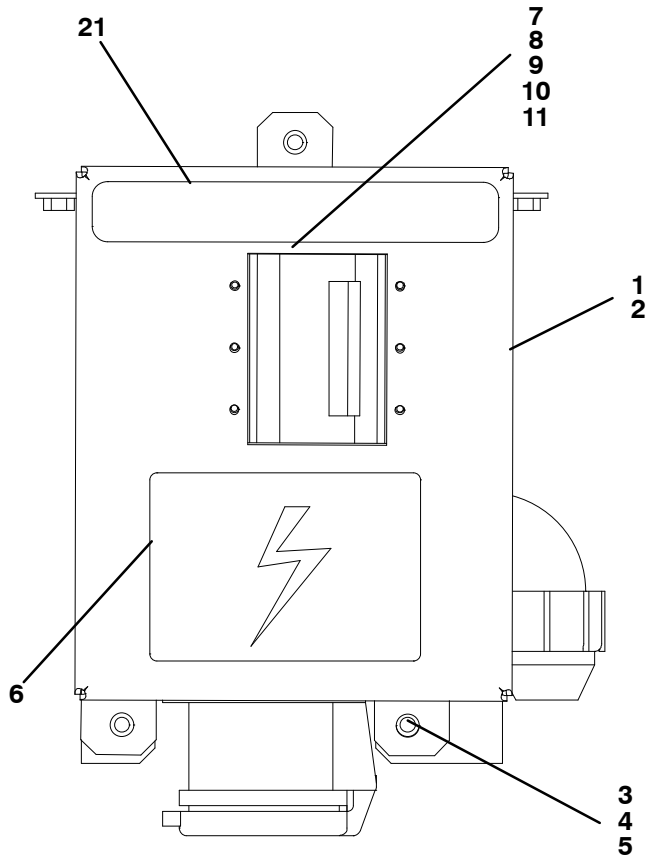

14.a,14.b,14.c RECEPTACLES (Continued)**RECEPTACLES – COMMON PARTS FOR OPTIONS 14.a,14.b,14.c**

Item	Part Number	Description	Qty
1	86-04273-00	Cover, Receptacle Box, Painted	1
2	42-00340-01	Gasket, Cover	1
3	66U1-5361-25	Screw, Hex Head, 1/4-20 x 0.75 Inch Long, SST	3
4	AU11JR171	Washer, Lock, 1/4, SST	3
5	66U1-5321-7	Washer, Plain, Type A, 1/4, SST	3
6	62-02948-01	Label, Danger High Voltage	1
7	66U1-7842-11	Circuit Breaker, 480 Volt	1
8	66U2-1391-1	Boot, Protective – Includes: (6) #6-32 x 1/2 Inch SST Screws	1
9	66CH1-1092-4	Boot, Frame, Painted	1
10	66U1-7842-6	Nut, Hex, Circuit Breaker, #10-32, Brass	6
11	66U1-7842-7	Washer, Flat, Circuit Breaker #10-32, Brass	12
12	66U1-8472-5	Connector, Watertight, 90 Degree, 1 Inch Hub	1
13	66U1-1251-3	O-Ring, Sealing, Zinc	1
14	34-06136-02	Nut, Lock, Nylon, 1.00 Inch NPT	1
15	66U1-5371-6	Screw, Hex Head Slotted, #10-24 x 0.75 Inch Long, SST	4
16	66U1-5331-3	Washer, Lock, #10, SST	4
17	66U1-5321-8	Washer, Plain, Type A, #10, SST	4
18	34-00372-41	Washer, Lock, External Tooth, 1/4, SST	3
19	34-00667-11	Nut, Self Locking, 1/4-20, SST	2
20	69NT41-982-2	Strap Assembly, Ground, Copper	1
14.a RECEPTACLE (91-00301-02) (INCLUDES COMMON PARTS AND ITEMS BELOW)			
21	62-10021-00	Label, Line Voltage	1
22	86-04272-01	Receptacle Box Assembly, Painted	1
23	22-01679-00	Receptacle, 32 Amp	1
14.b RECEPTACLE (91-00301-04) (INCLUDES COMMON PARTS AND ITEMS BELOW)			
22	86-04272-03	Receptacle Box Assembly, Painted	1
23	22-01938-00	Receptacle, 32 Amp	1
14.c RECEPTACLE (91-00301-05) (INCLUDES COMMON PARTS AND ITEMS BELOW)			
21	62-10021-00	Label, Line Voltage	1
22	86-04272-01	Receptacle Box Assembly, Painted	1
23	22-01679-02	Receptacle, 32 Amp	1

NOTE: See page ii for painted parts color system.

14.d RECEPTACLE WITH TIME DELAY (91-00340-00)

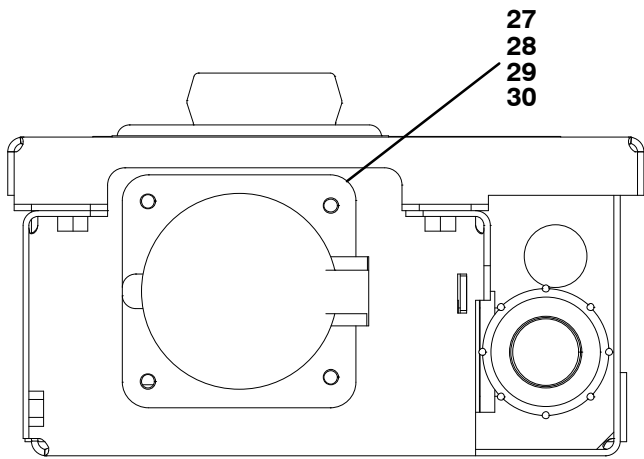
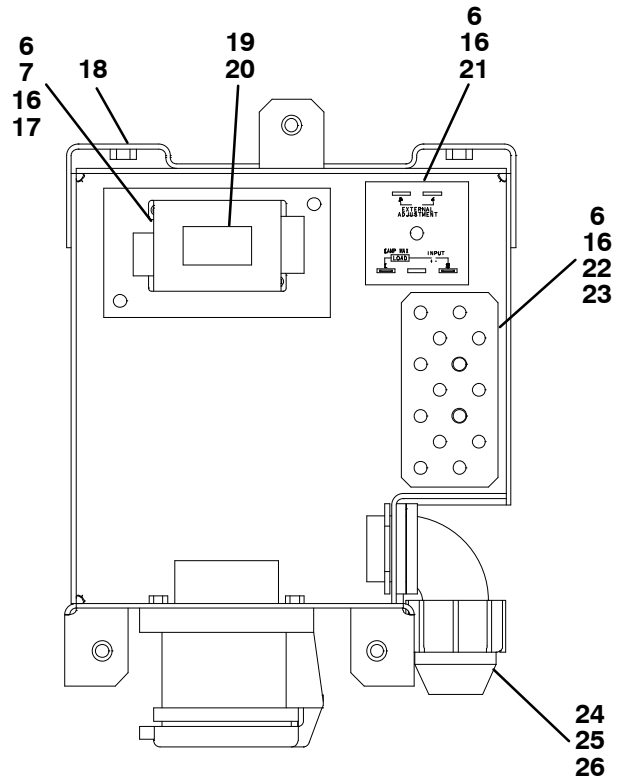
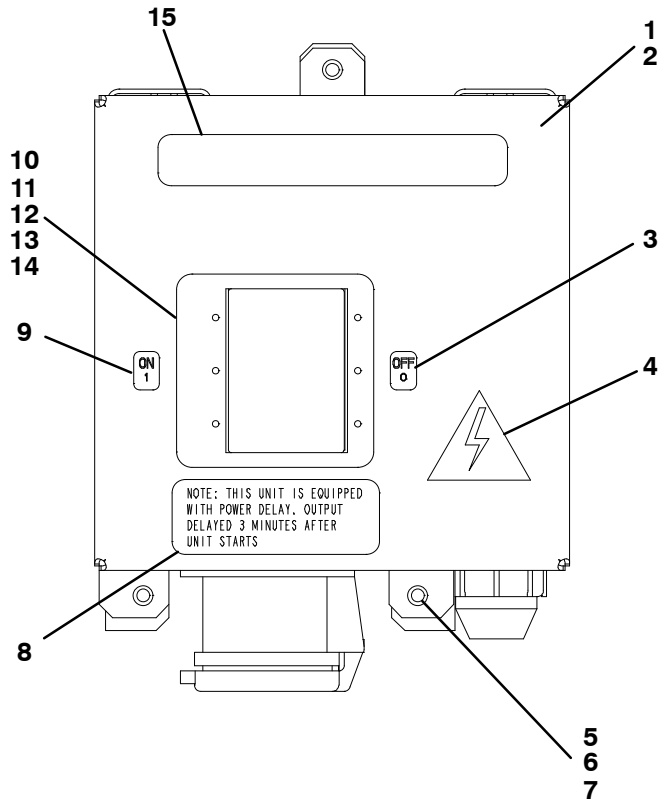

14.d RECEPTACLE WITH TIME DELAY (91-00340-00) (Continued)			
Item	Part Number	Description	Qty
1	86-04485-00	Cover, Receptacle Box, Painted	1
2	42-00550-00	Gasket, Cover	1
3	62-02670-01	Label, OFF 0	1
4	62-03957-04	Label, High Voltage Symbol	1
5	66U1-5361-25	Screw, Hex Head, 1/4-20 x 0.75 Inch Long, SST	3
6	66U1-5321-7	Washer, Plain, Type A, 1/4, SST	10
7	AU11JR171	Washer, Lock, 1/4, SST	5
8	62-11014-00	Label, Power Delay	1
9	62-02670-00	Label, ON 1	1
10	66U1-7842-11	Circuit Breaker, 480 Volt	1
11	66U2-1391-1	Boot, Protective, Circuit Breaker, With Hardware	1
12	66CH1-1092-4	Boot, Frame, Painted	1
13	66U1-7842-6	Nut, Hex, Circuit Breaker, #10-32, Brass	12
14	66U1-7842-7	Washer, Flat, Circuit Breaker #10-32, Brass	12
15	62-10021-00	Label, Line Voltage	1
16	34-00667-11	Nut, Self Locking, 1/4-20, SST	9
17	68-14179-01	Plate, Mounting, Contactor	1
18	86-04484-00	Receptacle Box Assembly, Painted	1
19	10-00433-00	Contactor, 30 Amp	1
20	34-06253-00	Screw, Socket Head, #8-32 x 0.50 Inch Long, SST	2
21	10-00461-00	Relay, Power, Time Delay	1
22	34-00372-41	Washer, Lock, External Tooth, 1/4, SST	2
23	69NT41-982-2	Strap Assembly, Ground, Copper	1
24	66U1-8472-5	Connector, Watertight, 90 Degree, 1 Inch Hub	1
25	66U1-1251-3	O-Ring, Sealing, Zinc	1
26	34-06136-02	Nut, Lock, Nylon, 1.00 Inch NPT	1
27	22-01679-00	Receptacle, 32 Amp	1
28	66U1-5371-6	Screw, Hex Head Slotted, #10-24 x 0.75 Inch Long, SST	4
29	66U1-5331-3	Washer, Lock, #10, SST	4
30	66U1-5321-8	Washer, Plain, Type A, #10, SST	4

14.e RECEPTACLE BOX ASSEMBLY

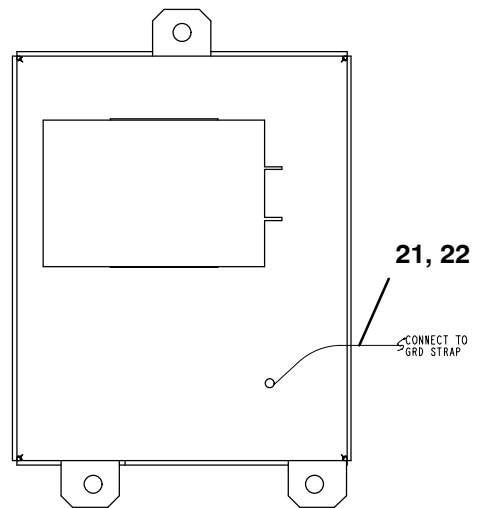
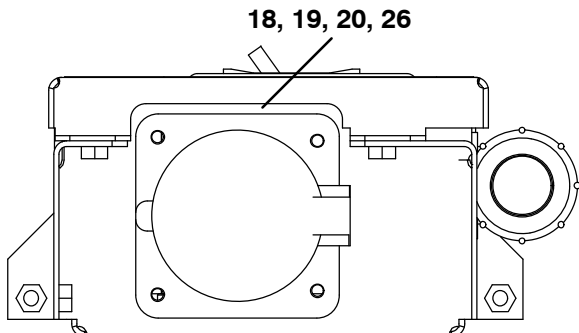
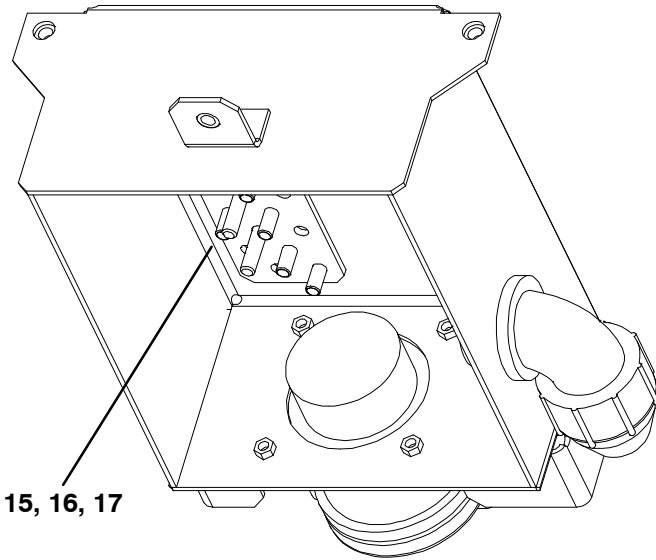
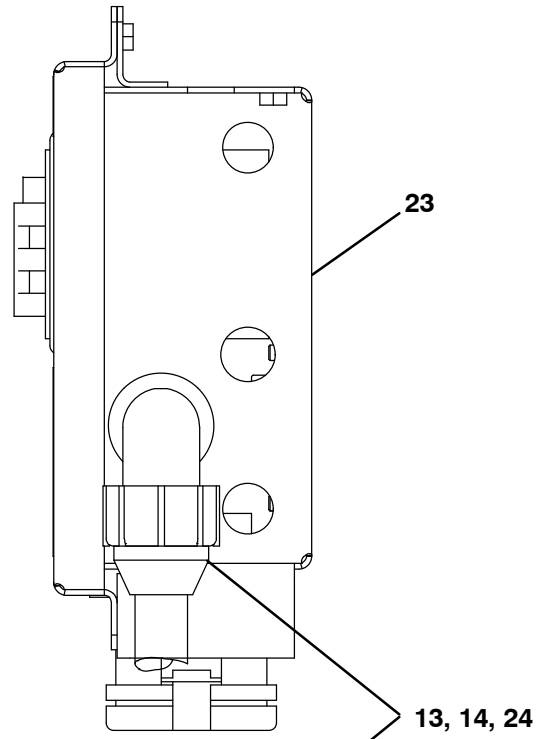
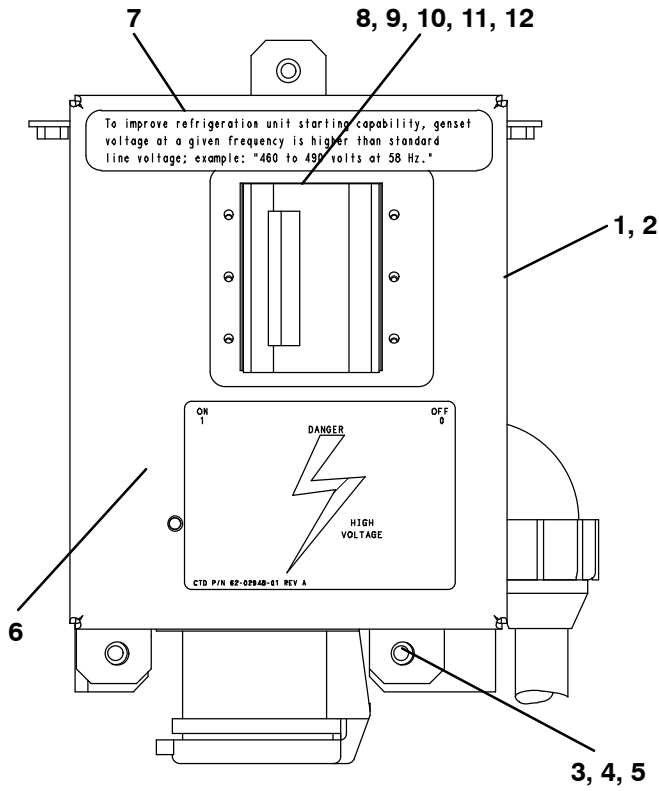

91-00408-

14.e RECEPTACLES – COMMON PARTS FOR OPTIONS 14.f,14.g,14.h, 14.i, 14.j (Continued)

Item	Part Number	Description	Qty
1	86-04273-00	Cover, Receptacle Box, Painted	1
2	42-00340-01	Gasket, Cover	1
3	66U1-5361-25	Screw, Hex Head, 1/4-20 x 0.75 Inch Long, SST	3
4	AU11JR171	Washer, Lock, 1/4, SST	3
5	66U1-5321-7	Washer, Plain, Type A, 1/4, SST	3
6	62-02948-01	Label, Danger High Voltage	1
7	62-10021-00	Label, Line Voltage	1
8	66U1-7842-11	Circuit Breaker, 480 Volt	1
9	66U2-1391-1	Boot, Protective – Includes: (6) #6-32 x 1/2 Inch SST Screws	1
10	66CH1-1092-4	Boot, Frame, Painted	1
11	66U1-7842-6	Nut, Hex, Circuit Breaker, #10-32, Brass	6
12	66U1-7842-7	Washer, Flat, Circuit Breaker #10-32, Brass	12
13	66U1-1251-3	O-Ring, Sealing, Zinc	1
14	34-06136-02	Nut, Lock, Nylon, 1.00 Inch NPT	1
15	34-00372-41	Washer, Lock, External Tooth, 1/4, SST	3
16	34-00667-11	Nut, Self Locking, 1/4-20, SST	2
17	69NT41-982-2	Strap Assembly, Ground, Copper	1
18	66U1-5371-6	Screw, Hex Head Slotted, #10-24 x 0.75 Inch Long, SST	4
19	66U1-5331-3	Washer, Lock, #10, SST	4
20	66U1-5321-8	Washer, Plain, Type A, #10, SST	4
21	34-00795-09	Nut, Self Lock, 10-32	1
22	34-00372-39	Washer, Lock, #10 Ext Tooth	1
14.f RECEPTACLE (91-00408-00) (INCLUDES COMMON PARTS AND ITEMS BELOW)			
23	86-04272-01	Box Assembly	1
24	66U1-8472-5	Connector 90 Degree	1
25	22-01764-01	Cable Assembly	1
26	22-01679-00	Receptacle	1
14.g RECEPTACLE (91-00408-01) (INCLUDES COMMON PARTS AND ITEMS BELOW)			
23	86-04272-01	Box Assembly	1
24	66U1-8472-5	Connector 90 Degree	1
25	22-01764-01	Cable Assembly	1
26	22-01679-02	Receptacle	1
14.h RECEPTACLE (91-00408-02) (INCLUDES COMMON PARTS AND ITEMS BELOW)			
23	86-04272-01	Box Assembly	1
24	66U1-8472-7	Connector 90 Degree	1
25	22-04223-00	Cable Assembly	1
26	22-01679-00	Receptacle	1
14.i RECEPTACLE (91-00408-03) (INCLUDES COMMON PARTS AND ITEMS BELOW)			
23	86-04272-04	Box Assembly	1
24	66U1-8472-7	Connector 90 Degree	1
25	22-04223-00	Cable Assembly	1
26	22-01679-02	Receptacle	1
14.j RECEPTACLE (91-00408-04) (INCLUDES COMMON PARTS AND ITEMS BELOW)			
23	86-04272-01	Box Assembly	1
24	66U1-8472-4	Connector 90 Degree	1
25	22-04223-01	Cable Assembly	1
26	22-01679-00	Receptacle	1

15 WIRE HARNESS

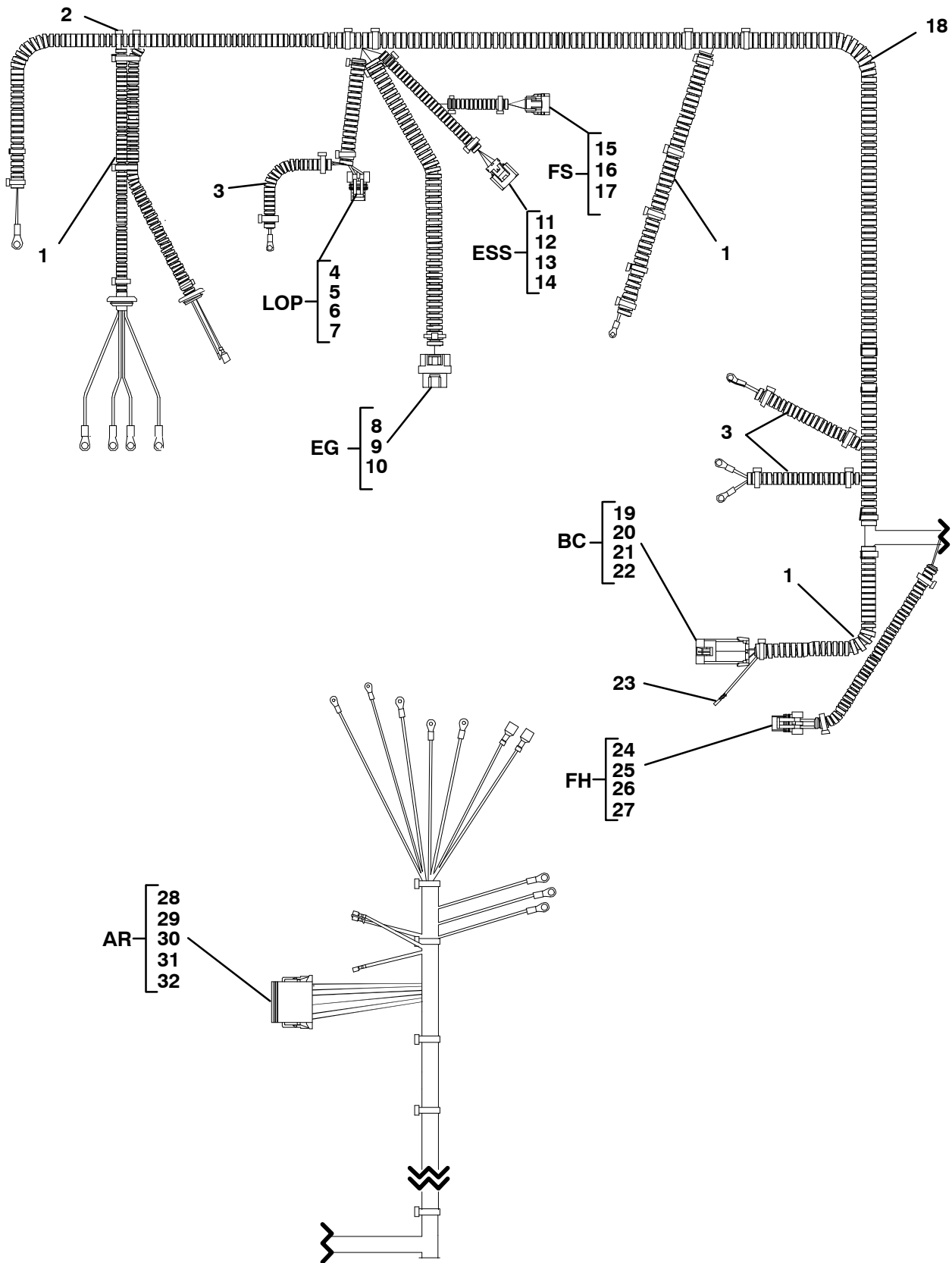

15 WIRE HARNESS (Continued)			
Item	Part Number	Description	Qty
15.a STANDARD WIRE HARNESS			
	22-04139-02	Wire Harness, Complete – Includes:	
	22-04139-05	Wire Harness, 2 Speed, Complete – Includes:	
	22-04139-06	Wire Harness, 2 Speed, Non-Selectable, Complete – Includes:	
1	58-00848-34	Tubing, Split, Corrugated, 1/2 Inch ID x 25 Feet Long	1
2	66U1-3882	Wire Tie, Self-Locking, 7.00 Inches, Black	57
3	58-00858-16	Tubing, Split, Corrugated, 1/4 Inch ID x 25 Feet Long	1
LOP		Low Oil Pressure Connector (LOP) – Includes:	
4	22-50078-02	Block	1
5	22-01756-01	Terminal	2
6	22-50078-51B	Seal, Cable	1
7	22-50078-01A	Secondary Lock	1
EG		Electronic Governor Module (EG) – Includes:	
8	22-50098-61	Block	1
9	22-50098-61C	Plug	1
10	22-50098-61A	Terminal	11
ESS		Engine Speed Sensor (ESS)– Includes:	
11	22-50098-50	Block	1
12	22-50098-50A	Terminal	3
13	22-50098-50E	Seal, Cable	3
14	22-50098-50D	Secondary Lock	1
FS		Fuel Solenoid (FS) – Includes:	
15	22-50098-62	Block	1
16	22-50098-62B	Cable Seal	2
17	22-50098-62C	Terminal	2
18	58-00906-15	Tubing, Split, Corrugated, 3/4 Inch ID x 25 Feet Long	1
BC		Battery Charger (BC) Connector – Includes:	
19	22-50078-39	Block	1
20	22-50078-39A	Secondary Lock	1
21	22-01756-00	Terminal	2
22	22-50078-52C	Cable Seal	2
23	22-01613-20	Contact, Socket, #14	1
FH		Fuel Heater (FH) Terminal – Includes:	
24	22-50078-02	Block	1
25	22-50078-01A	Secondary Lock	1
26	22-01756-02	Terminal	2
27	22-50078-51C	Cable Seal	2
15.b WIRE HARNESS WITH AUTO-RESTART (INCLUDES ALL OF OPTION 15.a AND ITEMS BELOW)			
	22-04139-00	Wire Harness, Complete – Includes:	
	22-04139-03	Wire Harness, 2 Speed, Complete – Includes:	
AR		Auto Restart (AR) Module – Includes:	
28	22-01613-25	Block	1
29	22-01613-13	Terminal	4
30	22-01613-20	Terminal	5
31	22-01613-29	Secondary Lock	1
32	22-01660-08	Seal	3
15.c WIRE HARNESS WITH AUTO-RESTART AND TIME DELAY (INCLUDES ALL OF OPTION 15.b AND ITEMS BELOW)			
	22-04139-01	Wire Harness, Complete – Includes:	
	22-04139-04	Wire Harness, 2 Speed, Complete – Includes:	

16 RETROFIT KITS			
Item	Part Number	Description	Qty
16.a RG T4I 2 Speed Standard			
1	74-00288-00	Retrofit Kit RG T4I 2 Speed Standard Includes	1
2	34-00658-10	Screw, Machine Hex Head #10-32 X 1-1/4	1
3	62-02669-02	Label, Ih/Ign/2Spd Switch	1
4	66U1-3882	Wire Tie 1/16-1-3/4	20
5	10-00475-00	Timer Time Delay, 2Hr	1
6	66CH1-1002-89	Label, Dt	1
7	10-01129-15	Switch,Toggle 1 Pole Off/On	1
8	22-04181-03	Wire Harness	1
9	62-11448-01	Label, Start/Stop 2Spd,A/R	1
10	62-11442-00	Label,Schematic 69Rg T4I Std,2 Spd	1
11	69GC15-3542	Bracket	1
12	66U1-5321-8	Washer, Plain 10 Type A	2
13	34-00665-09	Nut,Hex 10-32	1
14	66U1-5331-3	Washer,Lock 10 Spring	1
16.b RG T4I 2 Speed Auto Restart			
1	74-00290-00	Retrofit Kit T4I RG 2 Speed Auto Restart Includes	
2	34-00658-10	Screw, Machine Hex Head 10-32 X 1-1/4	1
3	62-02973-05	Label, ENGINE START, IGNITION, 2-SPEED	1
4	66U1-3882	Wire Tie 1/16-1-3/4	20
5	10-00475-00	Timer Time Delay, 2 Hour	1
6	66CH1-1002-89	Label Dt	1
7	10-01129-15	Switch,Toggle 1 Pole Off/On	1
8	22-04181-02	Wire Harness	1
9	62-11448-00	Label, Start/Stop 2Spd,Std	1
10	62-11443-00	Label,Schematic 69Rg,T4I,A/R,2 Spd	1
11	69GC15-3542	Bracket	1
12	66U1-5321-8	Washer,Plain 10 Type A	1
13	34-00665-09	Nut,Hex 10-32	1
14	66U1-5331-3	Washer,Lock 10 Spring	1

16 RETROFIT KITS (Continued)			
Item	Part Number	Description	Qty
16.c	RG T4I 2 Speed Auto With Fuel Warmer		
1	74-00299-00	Retrofit kit RG T4I 2 Speed W/ Fuel Warmer	1
2	34-00658-10	Screw,Mach Hexhead #10-32 X 1-1/4	1
3	62-02669-02	Label, lh/lgn/2Spd Switch	1
4	58-00079-02	Sta-Strap 0-1.75" Dia Cable	20
5	10-00475-00	Timer Time Delay, 2Hr	1
6	66CH1-1002-89	Label, Dt	1
7	10-01129-15	Switch,Toggle 1 Pole 0FF/On	1
8	22-04181-03	Wire Harness 69Rg T4I,2 Speed	1
9	62-11448-01	Label, Start/Stop 2 Speed	1
10	62-11442-00	Label,Schematic 69Rg T4I ,2 Speed	1
11	69GC-15-3542	Bracket	1
12	66U1-5321-8	Washer,Plain #10 Type A	2
13	34-00665-09	Nut,Hex #10-32	1
14	66U1-5331-3	Washer,Lock #10 Spring	1
15	44-00045-25	Clamp,Hose Worm Type	4
16	66U1-5321-3	Washer,Plain 1/4 N Type A	4
17	AU11JR171	Washer,Lock 1/4 Spring	4
18	66U1-5361-25	Screw,Cap Hex Head 1/4-20 X 0.75	4
19	66U1-8292-1	Cap,Insulating	2
20	30-00344-04	Fuel Warmer Diesel	1
21	44-00459-00	Clamp,Tube 1.69 Dia Cushion	1
22	58-04840-00	Hose,Formed Fuel Warmer	1
23	58-04839-00	Hose,Formed Fuel Warmer	1
24	68-15898-00	Bracket 69Rg Fuel Warmer	1
25	44-00045-02	Clamp,Hose .69-1.25 Worm Type	4
26	58-00658-23	Hose,Fuel 5/16 ID X 6 inch Long	1
27	58-00849-24	Tube,Slit 5/8 Id,5.00 inches Long	1
28	58-00658-24	Hose,Fuel 5/16 Id X 21 Long	1
29	58-00849-18	Tube,Slit 5/8 ID X8.50 Long	1
30	58-00850-24	Tube,Slit 1 Inch Od X 8 Inch Long	1
31	58-00850-25	Tube,Slit 1 Inch Od X 9.5Inch Long	1
32	58-00969-00	Wire Tie	1

16 RETROFIT KITS (Continued)			
Item	Part Number	Description	Qty
16.d	RG T4I 2 Speed Auto With Fuel Warmer And Auto Restart		
1	74-00301-00	Retrofit Kit RG T4I 2 Speed W/ Fuel Warmer And Auto Restart Includes	1
2	34-00658-10	Screw,Mach Hex Head 10-32 X 1-1/4	1
3	62-02973-05	Label, Eng Strt, Ign, 2 Spd	1
4	58-00079-02	Sta-Strap 0-1.75" Dia Cable	20
5	10-00475-00	Timer Time Delay, 2Hr	1
6	66CH1-1002-89	Label, Dt	1
7	10-01129-15	Switch,Toggle 1 Pole 0FF/On	1
8	22-04181-02	Wire Harness 69Rg T4I,A/R,2 Speed	1
9	62-11448-00	Label, Start/Stop 2 Speed	1
10	62-11443-00	Label,Schematic 69Rg,T4I,A/R,2 Speed	1
11	69GC15-3542	Bracket	1
12	66U1-5321-8	Washer,Plain #10 Type A	2
13	34-00665-09	Nut,Hex #10-32	1
14	66U1-5331-3	Washer,Lock #10 Spring	1
15	44-00045-25	Clamp,Hose	4
16	66U1-5321-3	Washer,Plain 1/4 N Type A	4
17	AU11JR171	Washer,Lock 1/4 Spring	4
18	66U1-5361-25	Screw,Cap Hex Head 1/4-20 X 0.75	4
19	66U1-8292-1	Cap, Insulating	2
20	30-00344-04	Fuel Warmer Diesel	1
21	44-00459-00	Clamp,Tube 1.69 Dia Cushion	1
22	58-04840-00	Hose,Formed Fuel Warmer	1
23	58-04839-00	Hose,Formed Fuel Warmer	1
24	68-15898-00	Bracket 69 Rg Fuel Warmer	1
25	44-00045-02	Clamp,Hose	4
26	58-00658-23	Hose,Fuel 5/16 ID X 6 inch Long	1
27	58-00849-24	Tube,Slit 5/8 Id,5.00 inches Long	1
28	58-00658-24	Hose,Fuel 5/16 Id X 21 Long	1
29	58-00849-18	Tube,Slit 5/8 ID X8.50 Long	1
30	58-00850-24	Tube,Slit 1 Inch Od X 8 Inch Long	1
31	58-00850-25	Tube,Slit 1 Inch Od X 9.5Inch Long	1
32	58-00969-00	Wire Tie	1

PART NUMBER INDEX

PART NO.	PAGE NO.	PART NO.	PAGE NO.	PART NO.	PAGE NO
0		2		22-50078-39	57
02-00083-00	7	22-00049-00	21	22-50078-39A	57
04-50012-00	7	22-00518-01	21	22-50078-51B	57
1		22-00519-01	21	22-50078-51C	57
10-00158-02	5	22-00538-01	24	22-50078-52C	57
10-00171-12	19, 22, 24	22-00538-01SV	19, 22	22-50098-50	57
10-00171-13	19, 22, 24	22-01030-54	19, 22, 25	22-50098-50A	57
10-00286-02	22	22-01576-06	31	22-50098-50D	57
10-00286-03	19	22-01613-13	57	22-50098-50E	57
10-00286-18	24	22-01613-20	57	22-50098-61	57
10-00328-00	19, 22, 25	22-01613-25	57	22-50098-61A	57
10-00365-00	19, 22, 24	22-01613-29	57	22-50098-61C	57
10-00365-10	19, 22, 25	22-01633-45	31	22-50098-62	57
10-00375-01	23, 26	22-01633-46	31	22-50098-62B	57
10-00433-00	53	22-01633-47	31	22-50098-62C	57
10-00448-00	18, 21, 24	22-01660-08	57	22-50206-00	7
10-00461-00	53	22-01679-00	51, 53, 55	26-00128-01	5
10-00469-00	19, 25	22-01679-02	51, 55	3	
10-00475-00	20, 25, 58 59, 60	22-01756-00	57	30-00328-00	17
10-01129-01	25	22-01756-01	57	30-00344-04	15, 59, 60
10-01129-13	19	22-01756-02	57	30-00358-04	31
10-01129-14	20, 24	22-01764-01	29, 55	30-00373-02	14, 15
10-01129-15	20, 58, 59 60	22-01790-02	24	30-00397-00	11
10-01129-18	21	22-01938-00	51	30-00424-02	33
10-01129-19	19, 24	22-02200-06	19, 22, 25	30-00426-05	17
12-00097-03	18, 21, 24	22-02205-00	35	30-00426-25	17
12-00098-04	5	22-04139-00	57	30-00427-00	33
12-00477-03	22	22-04139-01	57	30-00435-01	33
12-00592-00	5	22-04139-02	57	30-00460-04	27
12-01098-03	13, 15	22-04139-03	57	30-00473-03	16
12-01098-05	15	22-04139-04	57	30-00473-20	16
12-01098-07	15	22-04139-05	57	30-01104-13	13
12-01098-08	15	22-04139-06	24, 57	34-00304-08	7
		22-04181-02	58, 60	34-00372-39	25, 55
		22-04181-03	58, 59	34-00372-41	22, 25, 29 51, 53, 55
		22-04223-00	55	34-00372-44	31
		22-04223-01	55	34-00588-11	37, 39, 41 47, 49
		22-50078-01A	57		
		22-50078-02	57		

PART NUMBER INDEX

PART NO.	PAGE NO.	PART NO.	PAGE NO.	PART NO.	PAGE NO
34-00655-04	5, 7, 29	34-00928-13	37, 39, 41 43, 45, 47 49	34-06229-00	9
34-00655-06	7			34-06247-02	31
34-00655-08	11, 13, 37 39, 41, 45 47, 49	34-00932-13	33	34-06253-00	53
34-00658-10	58, 59, 60	34-00945-06	5	34-06278-00	7
34-00662-11	5	34-00964-00	33		
34-00662-12	7, 29, 31 37, 39, 41 43, 45, 47 49	34-01142-01	37, 49	4	
34-00663-11	13	34-01145-06	5	40-00043-05	5
34-00663-12	11, 13, 37 39, 41, 43 45, 47, 49	34-01146-08	5, 33	40-00067-01	5
34-00665-09	25, 58, 59 60	34-01146-10	11	40-00107-01	5
34-00666-08	19, 22, 25	34-01146-12	11, 29	40-00117-01	11
34-00667-05	18, 21, 25	34-01151-08	5, 31, 33	40-00213-00	13
34-00667-07	19, 22, 25	34-01151-10	11	40-00420-01	13
34-00667-11	11, 16, 17 19, 22, 25 51, 53, 55	34-01151-12	11, 29	40-00469-00	13
34-00667-12	9, 13, 29 31	34-01153-15	5, 31, 33	40-00512-00	17
34-00667-13	5, 9	34-01153-82	5	40-00566-00	5
34-00667-15	5	34-01154-25	11	40-00697-00	13
34-00792-10	13	34-01155-25	11, 29	40-00708-00	14, 15
34-00795-09	19, 25, 55	34-01219-03	37, 39, 41 45, 47	40-01156-00	13
34-00795-17	5	34-01226-00	37, 49	40-01176-52	17
34-00804-18	5	34-06014-12	27	42-00243-14	21
34-00807-04	5	34-06051-07	37, 39, 41 45, 47, 49	42-00264-09	11
34-00807-08	27	34-06051-40	47	42-00340-01	51, 55
34-00807-10	5	34-06053-03	37, 49	42-00341-00	19, 22, 25
34-00807-12	5	34-06060-01	5	42-00348-00	7, 27
34-00829-13	5, 27	34-06107-00	41	42-00363-00	37, 39, 41 43, 45, 47 49
34-00829-15	5	34-06136-02	29, 51, 53 55	42-00363-01	37, 39, 41 43, 45, 47 49
34-00833-24	5	34-06149-02	9	42-00481-00	22
34-00890-08	5	34-06149-03	9	42-00486-01	37, 39, 41 43
34-00890-09	5	34-06154-01	47	42-00550-00	53
34-00928-01	37, 49	34-06154-02	47	42-01133-00	13
34-00928-03	19, 22, 25	34-06170-08	9	42-50010-00	7
		34-06200-00	9	44-00045-02	15, 59, 60
		34-06201-00	9	44-00045-25	13, 59, 60
		34-06205-00	9	44-00046-13	14, 15
		34-06207-00	9	44-00046-14	15
		34-06212-12	13		

PART NUMBER INDEX

PART NO.	PAGE NO.	PART NO.	PAGE NO.	PART NO.	PAGE NO
66CH1-1092-4	51, 53, 55	66U1-5361-38	13, 37, 39 41, 43, 45 47, 49	68-14179-01	53
66CH1-1172-59	37, 39, 41 43, 49	66U1-5361-39	11, 37, 39 41, 43 45, 47, 49	68-14698-01	7
66CH1-123-100	5	66U1-5361-47	29	68-14699-01	7
66U1-1251-3	29, 51, 53 55	66U1-5361-6	11	68-15575-00	37
66U1-2552-124	37, 39, 41 43, 45, 47 49	66U1-5371-6	51, 53, 55	68-15898-00	15, 59, 60
66U1-2823	19, 21, 24	66U1-6651-15	18, 21, 25	69GC-15-3212	13
66U1-2823-3	5	66U1-6811-12	37, 49	69GC-15-3542	59
66U1-3662-21	19, 22, 25	66U1-7842-11	51, 53, 55	69GC15-1602	9
66U1-3882	11, 19, 22 29, 31, 41 57, 58	66U1-7842-6	51, 53, 55	69GC15-3542	20, 21, 25 58, 60
66U1-5321-11	5	66U1-7842-7	51, 53, 55	69GS4-1582-1	18, 23, 25 26
66U1-5321-2	19, 22, 25	66U1-8292-1	59, 60	69GS4-1702	35
66U1-5321-3	7, 16, 17 18, 22, 25 27, 31, 37 39, 41, 43 45, 47, 49 59, 60	66U1-8472-4	55	69NT35-2692-1	11, 29
66U1-5321-4	9, 11, 13	66U1-8472-5	29, 51, 53 55	69NT41-982-2	19, 22, 25 51, 53, 55
66U1-5321-5	5, 33	66U1-8472-7	55		
66U1-5321-7	11, 29, 51 53, 55	66U1-8772	19, 25	7	
66U1-5321-8	19, 25, 51 53, 55, 58 59, 60	66U1-9592-13	19, 22, 25	73-00175-01	5
66U1-5321-9	5	66U1-9752	19, 21, 25	73-00198-00	5
66U1-5331-3	19, 22, 25 51, 53, 55 58, 59, 60	66U2-1391-1	51, 53, 55	73-00305-00	5
66U1-5331-4	19, 22, 25	68-12110-02	39, 43, 45	74-00288-00	58
66U1-5331-8	5, 9	68-12110-03	41	74-00290-00	58
66U1-5331-9	5	68-12110-04	47	74-00299-00	59
66U1-5361-14	11	68-12132-00	27	74-00301-00	60
66U1-5361-25	11, 16, 17 19, 22, 25 29, 31, 37 39, 41, 43 47, 49, 51 53, 55, 59 60	68-12166-00	5	76-50110-00	7
66U1-5361-36	5	68-12174-00	5	79-01674-05	39, 41, 43 45
		68-12186-00	37, 39, 41 43	79-01674-06	47
		68-12536-00	37	79-01674-08	37, 49
		68-12540-00	37, 49	79-01909-07	35
		68-12838-00	33		
		68-12973-00	19, 25	8	
		68-12996-01	9	81-04054-00	11
		68-12997-00	9	81-04100-00	13
		68-12998-00	9	86-04165-04	19
		68-12998-01	9	86-04165-05	22
		68-13483-00	37, 49	86-04165-08	20
		68-13946-00	31		

PART NUMBER INDEX

PART NO.	PAGE NO.	PART NO.	PAGE NO.	PART NO.	PAGE NO		
86-04165-09	23, 26	86-04676-00	5	A			
86-04165-10	24	86-04677-00	31				
86-04182-00	5	86-04680-00	39, 41		AA06BZ300	5	
86-04231-05	22	86-04680-01	45		AT39QA132	19, 22, 25	
86-04231-06	22	86-04680-02	43		AU11JR171	5, 7, 11 19, 22, 25 27, 29, 31 37, 39, 41 43, 51, 53 55, 59, 60	
86-04231-07	19	86-04680-03	49				
86-04231-08	26	86-04680-04	47				
86-04231-09	23	86-04752-00	27				
86-04231-10	20, 24				AU11JR241	5, 27, 33	
86-04272-01	51, 55				AU53VA061	41	
86-04272-03	51	9					
86-04272-04	55		91-00398-00	22			
86-04273-00	51, 55		91-00398-01	22	K		
86-04288-01	11		91-00398-02	19			
86-04470-00	11		91-00398-03	23		KA69JM824	11
86-04484-00	53		91-00398-04	26		KA69JM840	16, 17
86-04485-00	53		91-00398-05	20		KK71EW223	18, 21, 25
86-04674-00	5		91-00407-07	24		KK71GW007	19, 22, 25
86-04675-00	11						



A member of the United Technologies Corporation family. Stock symbol UTX
©2010 Carrier Corporation • Printed in U. S. A. 03/14



Carrier Transicold Division,
Carrier Corporation
Container Products Group
P.O. Box 4805
Syracuse, N.Y. 13221 U.S.A

www.carrier.transicold.com

